

SAPULPA CITY COUNCIL MEETING

CITY HALL - 425 EAST DEWEY AVENUE

COUNCIL CHAMBERS, 2ND FLOOR

7:00 P.M., MONDAY, APRIL 20, 2020

Notice is hereby given that the Mayor and City Council of the City of Sapulpa, Oklahoma, will meet in regular session at 7:00 p.m. on the 20th day of April, 2020, in the Council Chambers, Sapulpa City Hall, 425 East Dewey Avenue, Sapulpa, Oklahoma, with the agenda for said meeting as follows:

MEETING PROCEDURE: Comments from the public are welcome at two different times during the course of the meeting. A **Sign in Sheet** is located at the back of the room. Those wishing to address the City Council are to sign in prior to the start of the meeting and identify the item(s) they wish to address. Comments concerning items scheduled on the Agenda will be heard immediately following the presentation by staff or petitioner. Comments concerning items not scheduled on the Agenda will only be heard under the Public Comments section. The City Council will not act on any matter discussed in the Public Comments section and will act on the Item on the Agenda after all comments have been heard.

Please come to the podium when the Mayor calls your name.

- AGENDA -

1. **NOTICE OF TELECONFERENCE AND/OR VIDEO CONFERENCE PARTICIPATION:**
 - A. The following City Councilors will remotely appear and participate in the regular meeting by telephonic connection:

John Anderson, Vickie Beyer, Bruce Bledsoe, Marty Cummins, Wes Galloway, Carla Gunn, Craig Henderson, Louis Martin, Jr., Hugo Naifeh, John Suggs.
 - B. All Council members may choose to appear physically and participate in the meeting at the City Council chambers if desired.
 - C. The meeting is open and accessible to the public by telephonic connection at #1-346-248-7799; Meeting ID: 967 5444 2312. In addition, the meeting is open and accessible for public participation by on site appearance at the Sapulpa City Council Chamber, at 425 E Dewey Avenue, Sapulpa, Oklahoma.
2. **CALL TO ORDER.**
3. **INVOCATION.**
4. **PLEDGE OF ALLEGIANCE.**

5. **ROLL CALL.**

6. **MINUTES.**

- A. Consider approving the minutes of the April 6, 2020, regular city council meeting.
- B. Consider approving the minutes of the April 2, 2020, emergency city council meeting.

7. **APPOINTMENTS, AWARDS, PRESENTATIONS, AND PROCLAMATIONS.**

8. **CONSENT ITEMS:** All matters under “Consent” are considered by the City Council to be routine and will be enacted by one motion. Any City Council member may, however, remove an item from consent by request.

- A. Consider approving claims in the amount of \$498,528.34
- B. Consider approving prepaid claims in the amount of \$2,136.84

9. **PUBLIC HEARINGS.**

10. **COMMUNITY DEVELOPMENT.**

11. **ADMINISTRATION.**

- A. Discussion and possible action regarding a Resolution of the City of Sapulpa, Oklahoma and the Sapulpa Municipal Authority amending the FY 2019-2020 annual budget by increasing revenue and appropriations in the Stormwater Management Fund in the amount of \$11,385.00 to recognize reimbursements for damage to the sewer vac truck.
- B. Discussion and possible action regarding a Resolution of the City of Sapulpa, Oklahoma and the Sapulpa Municipal Authority amending the FY 2019-2020 annual budget by increasing revenue and appropriations in the Water and Sewer Sales Tax Fund in the amount of \$3,900.00 to recognize reimbursements for damage to a fire hydrant.
- C. Discussion and possible action regarding approval of a straight line of credit "SLOC") from American Heritage Bank for \$550,000.00 to provide interim short-term funding for 2020 GO bond projects, and authorization for the City Manager to execute all necessary and related documentation.

- D. Discussion and possible action regarding a Resolution of the City of Sapulpa, Oklahoma amending the FY 2019-2020 annual budget by increasing revenue and appropriations in the GO Bond Construction Fund to recognize proceeds from a Line of Credit issued by American Heritage Bank in the amount of \$550,000.00 for interim short-term funding for projects.
- E. Discussion and possible action regarding award of Bid No. COS-10079 for the Replacement of Roof Top HVAC Units (Sapulpa Police Department) Project, as follows: (i) rejecting apparent low bid of \$254,480.00 from Air Conditioning Service Inc., for failure to meet bid specifications, and (ii) awarding bid to Powers Mechanical Service, as being the lowest, responsive and responsible bidder, in the amount of \$256,530.11, and authorize the Mayor/Chairman to execute all contract documents related thereto.
- F. Discussion and possible action regarding Agreement for Professional Services with Olsson, Inc. dba Oschner Hare & Hare the Olsson Studio ("Olsson") for creation of a Downtown Sapulpa Master Plan in the amount of \$197,000.00.
- G. Discussion and possible action regarding modified Agreement with ESRI to expand the City's current licensing to provide ArcGIS Mapping for the City of Sapulpa at an additive cost amount of \$4,030.00.
- H. Discussion and possible action regarding a Disaster Assistance Agreement for Major Disasters between the State of Oklahoma and the City of Sapulpa for disaster assistance resulting from Oklahoma DR 4530 COVID-19 and authorize the Mayor Pro Tem to execute all necessary documents.
- 12. **NEW BUSINESS.** (Items that were not known about at the time of posting the agenda.)
- 13. **INFORMATIONAL ITEMS FROM MAYOR, CITY COUNCIL, CITY MANAGER, OR CITY ATTORNEY.**
- 14. **PUBLIC COMMENTS.** The purpose of the Public Comments Section of the Agenda is for members of the public to speak to the City Council on any subject not scheduled on the Regular Agenda. City Council shall make no decision or action, except to direct the City Manager to take action, or to schedule the matter for City Council discussion at a later date.

Please come to the podium when the Mayor calls your name and keep your comments as brief as possible.
- 15. **EXECUTIVE SESSION.**
- 16. **ADJOURNMENT.**

Posted this 17th day of April, 2020 at or before 5:30 p.m., at the Sapulpa City Hall, 425 East Dewey Avenue, Sapulpa, Oklahoma.

Name: *Amy Hoehner*

Title: *Legal Assistant*



AGENDA ITEM

City Council Regular

6. A.

Meeting Date: April 20, 2020

Submitted By: Shirley Burzio, City Clerk

Department: City Clerk

Presented By:

SUBJECT:

Consider approving the minutes of the April 6, 2020, regular city council meeting.

BACKGROUND:

RECOMMENDATION:

Attachments

[minutes.04-06-2020 city](#)

CITY OF SAPULPA, OKLAHOMA
COUNCIL PROCEEDINGS
Meeting of April 6, 2020

The City Council of Sapulpa, Oklahoma, met in regular session Monday, April 6, 2020, at 7:00 o'clock P.M. in the City Hall Council Chambers, 425 East Dewey Avenue, Sapulpa, Oklahoma.

Present: Louis Martin, Jr., Mayor Pro Tem
Marty Cummins, Vice-Mayor Pro Tem
John Anderson, Councilor
Vicki Beyer, Councilor
Bruce Bledsoe, Councilor
Wes Galloway, Councilor
Carla Gunn, Councilor
Craig Henderson, Councilor
Hugo Naifeh, Councilor
John Suggs, Councilor

Staff Present: City Manager Joan Riley; City Treasurer / Finance Director Pam Vann; City Attorney David Widdoes; City Clerk Shirley Burzio; Public Works Director Steve Hardt; Urban Development Director Nikki Howard

1. NOTICE OF TELECONFERENCE PARTICIPATION:

- A.** The following City Councilors remotely appeared and participated in the regular meeting by telephonic connection:

Vickie Beyer, Marty Cummins, Carla Gunn, John Suggs.

- B.** All Council members may choose to appear physically and participate in the meeting at the City Council chambers if desired.

- C.** The meeting was open and accessible to the public by telephonic connection at #1-346-248-7799; Meeting ID: 460 229 466. In addition, the meeting was open and accessible for public participation by on site appearance at the Sapulpa City Council Chamber, at 425 E Dewey Avenue, Sapulpa, Oklahoma.

2. INVOCATION.

The invocation was given by Rev. Mike Peters, Canyon Road Baptist Church.

3. PLEDGE OF ALLEGIANCE.

Mayor Louis Martin led the Pledge of Allegiance

4. MINUTES.

- A. Consider approval of minutes for the March 16, 2020, regular city council meeting.
- B. Consider approval of minutes for the March 23, 2020, special city council meeting.

Motion was made by Hugo Naifeh, second by Craig Henderson to approve the minutes of the March 16, 2020, regular city council meeting and the March 23, 2020, special city council meeting.

ROLL CALL VOTE - AYE: Louis Martin, Jr., Marty Cummins, John Anderson, Vicki Beyer, Bruce Bledsoe, Wes Galloway, Carla Gunn, Craig Henderson, Hugo Naifeh, John Suggs

10 - 0 MOTION CARRIED

5. APPOINTMENTS, AWARDS, PRESENTATIONS, AND PROCLAMATIONS.

- A. Discuss and consider approving a proclamation proclaiming the week of April 12 through 18, 2020, as National Public Safety Telecommunications Week in the City of Sapulpa.
- B. Discuss and consider approving proclamation proclaiming week of April 12 through 18, 2020, to be National Animal Control Officers Appreciation Week in the City of Sapulpa.

Motion was made by Craig Henderson, second by Wes Galloway to approve proclamations proclaiming the week of April 12 through 18, 2020, as National Public Safety Telecommunications Week and the week of April 12 through 18, 2020, as National Animal Control Officers Appreciation Week in the City of Sapulpa.

ROLL CALL VOTE - AYE: Louis Martin, Jr., Marty Cummins, John Anderson, Vicki Beyer, Bruce Bledsoe, Wes Galloway, Carla Gunn, Craig Henderson, Hugo Naifeh, John Suggs

10 - 0 MOTION CARRIED

6. CONSENT ITEMS:

- A. Consider approving pre-paid claims in the amount of \$17,277.35
- B. Consider approving claims in the amount of \$170,650.15

Motion was made by John Anderson, second by Wes Galloway to approve pre-paid claims in the amount of \$17,277.35 and claims in the amount of \$170,650.15.

ROLL CALL VOTE - AYE: Louis Martin, Jr., Marty Cummins, John Anderson, Vicki Beyer, Bruce Bledsoe, Wes Galloway, Carla Gunn, Craig Henderson, Hugo Naifeh, John Suggs

10 - 0 MOTION CARRIED

7. PUBLIC HEARINGS.

- A. Consider conducting a public hearing to receive input and recommendations on community needs for the City of Sapulpa as a member of the Tulsa County Community Development Block Grant (CDBG) Urban County.

A public hearing was held. There were no written or oral comments made to the council.

8. ADMINISTRATION.

- A. Discussion and possible action regarding an ordinance of the City of Sapulpa, Oklahoma, amending Part 13, Public Safety, Chapter 4, Civil Emergency Management, by adding new Section 13-411, Violation and Penalties; providing for an effective date; repealing all ordinances or parts of ordinances in conflict with this ordinance; and providing that if any part or parts of this ordinance are held invalid or ineffective, the remaining portions shall not be affected; and declaring an emergency. (Ordinance No. 2832)

Motion was made by Bruce Bledsoe, second by Hugo Naifeh to approve the adoption of said ordinance.

ROLL CALL VOTE - AYE: Louis Martin, Jr., Marty Cummins, John Anderson, Vicki Beyer, Bruce Bledsoe, Wes Galloway, Carla Gunn, Craig Henderson, Hugo Naifeh, John Suggs

10 - 0 MOTION CARRIED

Motion was made by Bruce Bledsoe, second by Craig Henderson to approve the adoption and passage of the emergency clause.

ROLL CALL VOTE - AYE: Louis Martin, Jr., Marty Cummins, John Anderson, Vicki Beyer, Bruce Bledsoe, Wes Galloway, Carla Gunn, Craig Henderson, Hugo Naifeh, John Suggs

10 - 0 MOTION CARRIED

- B.** Discussion and possible action regarding a resolution relating to \$13,000,000.00 General Obligation Bonds, Series 2020A; fixing the amount of bonds to mature each year, fixing the time and place the bonds are to be sold, and authorizing the Mayor to give notice of said sale as required by law. (Resolution No. 4620)

Motion was made by Hugo Naifeh, second by Bruce Bledsoe to approve the adoption of said resolution.

ROLL CALL VOTE - AYE: Louis Martin, Jr., Marty Cummins, Vicki Beyer, Bruce Bledsoe, Wes Galloway, Carla Gunn, Craig Henderson, Hugo Naifeh, John Suggs

NAY: John Anderson

9 - 1 MOTION CARRIED

- C.** Discussion and possible action regarding a resolution relating to \$2,000,000.00 General Obligation Limited Tax Bonds, Taxable Series 2020; fixing the amount of bonds to mature each year, fixing the time and place the bonds are to be sold, and authorizing the Mayor to give notice of said sale as required by law. (Resolution No. 4621)

Motion was made by Hugo Naifeh, second by Bruce Bledsoe to approve the adoption of said resolution.

ROLL CALL VOTE - AYE: Louis Martin, Jr., Marty Cummins, John Anderson, Vicki Beyer, Bruce Bledsoe, Wes Galloway, Carla Gunn, Craig Henderson, Hugo Naifeh, John Suggs

10 - 0 MOTION CARRIED

- D.** Discussion and possible action regarding recommendation to award bid to Crossland Heavy Contractors, Inc., in the amount of \$3,759,464.00 for the Wastewater Treatment Plant Improvements Project, and authoring the Mayor Pro Tem to execute all contract documents related thereto. The budgeted amount for the project is \$3,817,650.00.

Motion was made by John Anderson, second by Wes Galloway to award the bid for the Wastewater Treatment Plant Improvements Project to Crossland Heavy Contractors, Inc., in the amount of \$3,759,464.00 and to authorize the Mayor Pro Tem to execute all contract documents related thereto.

ROLL CALL VOTE - AYE: Louis Martin, Jr., Marty Cummins, John Anderson, Vicki Beyer, Bruce Bledsoe, Wes Galloway, Carla Gunn, Craig Henderson, Hugo Naifeh, John Suggs

10 - 0 MOTION CARRIED

- E.** Discussion and possible action regarding recommendation to approve Change Order #1 in the amount of \$149,335.00 to the contract with Cherokee Pride Construction for the North Hickory Road Project.

Motion was made by Hugo Naifeh, second by John Anderson to approve Change Order #1, in the amount of \$149,335.00, to the contract with Cherokee Pride Construction for the North Hickory Road Project.

ROLL CALL VOTE - AYE: Louis Martin, Jr., Marty Cummins, John Anderson, Vicki Beyer, Bruce Bledsoe, Wes Galloway, Carla Gunn, Craig Henderson, Hugo Naifeh, John Suggs

10 - 0 MOTION CARRIED

- F.** Discussion and possible action to change, revise and/or amend the third proclamation of the City of Sapulpa, Oklahoma, further declaring state of emergency, dated April 2, 2020, from the COVID-19 public health crisis.

Motion was made by Bruce Bledsoe, second by Hugo Naifeh to maintain the current proclamation as is and with no changes.

ROLL CALL VOTE - AYE: Louis Martin, Jr., Marty Cummins, John Anderson, Vicki Beyer, Bruce Bledsoe, Wes Galloway, Carla Gunn, Craig Henderson, Hugo Naifeh

NAY: John Suggs

9 - 1 MOTION CARRIED

9. PUBLIC COMMENTS.

Mr. Troy Bundy, owner of property located at 519 West Dewey Avenue, told the council the property had sustained tornado damage. The city abated the property, and ordered that the property be demolished. He requested a continuance, so he could deal with the insurance company.

Mr. Bundy was advised that the council could not take any action on his request.

10. ADJOURNMENT.

Motion was made by John Anderson, second by Wes Galloway to adjourn the meeting.

ROLL CALL VOTE - AYE: Louis Martin, Jr., Marty Cummins, John Anderson, Vicki Beyer, Bruce Bledsoe, Wes Galloway, Carla Gunn, Craig Henderson, Hugo Naifeh, John Suggs

10 - 0 MOTION CARRIED

Mayor

Attest:

City Clerk



AGENDA ITEM

City Council Regular

6. B.

Meeting Date: April 20, 2020

Submitted By: Shirley Burzio, City Clerk

Department: City Clerk

Presented By:

SUBJECT:

Consider approving the minutes of the April 2, 2020, emergency city council meeting.

BACKGROUND:

RECOMMENDATION:

Attachments

minutes.04-02-2020 city emergency

CITY OF SAPULPA, OKLAHOMA
COUNCIL PROCEEDINGS
Emergency Meeting of April 2, 2020

The City Council of Sapulpa, Oklahoma, met in an emergency session Thursday, April 2, 2020, at 7:00 o'clock P.M. in the City Hall Council Chambers, 425 East Dewey Avenue, Sapulpa, Oklahoma.

Present: Louis Martin, Jr., Mayor Pro Tem
Marty Cummins, Vice-Mayor Pro Tem
John Anderson, Councilor
Vicki Beyer, Councilor
Bruce Bledsoe, Councilor
Wes Galloway, Councilor
Carla Gunn, Councilor
Craig Henderson, Councilor
Hugo Naifeh, Councilor
John Suggs, Councilor

Staff Present: City Manager Joan Riley; City Attorney David Widdoes;
City Clerk Shirley Burzio;

1. NOTICE OF TELECONFERENCE PARTICIPATION:

- A.** The following City Councilors appeared remotely and participated in the emergency meeting by telephonic connection:

John Anderson, Bruce Bledsoe, Marty Cummins, Carla Gunn, and John Suggs.

- B.** The council chambers was open for public participation.

2. ADMINISTRATION.

- A.** Discussion and possible action regarding Third Emergency Proclamation amending, and/or revising prior Mayoral declarations of emergency from the COVID-19 crisis.

City Attorney David Widdoes told the council that Governor Stitt had declared a catastrophic health emergency for the State of Oklahoma earlier in the day (April 2, 2020) because of the COVID-19 virus pandemic. In order to protect the health and safety of the City of Sapulpa and its inhabitants, and to preserve the peace, and to provide civil defense and emergency functions, an emergency meeting of the city council was necessary.

Motion was made John Anderson, seconded by Vicki Beyer to approve the adoption of the proclamation.

ROLL CALL VOTE - AYE: Louis Martin, Jr., Marty Cummins, Vicki Beyer, Bruce Bledsoe, Wes Galloway, Carla Gunn, Craig Henderson, Hugo Naifeh, John Suggs

9 - 0 MOTION CARRIED

Due to audio difficulties, the vote cast by Councilor John Anderson via telephonic connection could not be heard by the council, staff and audience.

3. ADJOURNMENT.

Motion was made Wes Galloway, seconded by Hugo Naifeh to adjourn the meeting. Motion carried unanimously.

Mayor

Attest:

City Clerk



Consent Agenda 8. A.

City Council Regular

Meeting Date: April 20, 2020

Submitted For: Hailey Sharp, Accounts Payable Clerk

Submitted By: Amber Fisher, Accounts Payable Clerk

SUBJECT:

Consider approving claims in the amount of \$498,528.34

Attachments

Claims List 4/20/2020

FUND: 10 - GENERAL FUND

SUMMARY REPORT

P.O.#	VENDOR #	NAME	SUMMARY DESCRIPTION	DATE	INVOICE	AMOUNT
127498	99-10031	THE SPYGLASS GROUP, LLC	COST RECOVERY/PHONES	4/2020	1/31/2020 127498	1,467.48
127451	99-10143	PERDUE, BRANDON, FIELDER,	CCOLLECTION SERVICES	4/2020	3/1-3/31/20 127451	6,549.66
129882	99-10159	LAWRENCE COUNTY NEWSPAPERS,	PUBL ORD/RESOLUTION	4/2020	24217	85.35
130001	99-10159	LAWRENCE COUNTY NEWSPAPERS,	ADD FOR INCINERATOR	4/2020	24218	70.40
129022	99-10160	MERRIFIELD OFFICE SOLUTIONS	JANITORIAL SUPPLIES	4/2020	188806-001	31.99
129391	99-10160	MERRIFIELD OFFICE SOLUTIONS	PENS, PAPER, FOLDERS	4/2020	191932-001	53.52
130010	99-10160	MERRIFIELD OFFICE SOLUTIONS	JANITORIAL SUPPLIES	4/2020	0191468-001	272.21
129795	99-10252	CECIL COX ENTERPRISES	FRONT END ALIGNMENT #2719	4/2020	3057614	59.95
129832	99-103	ONG	ONG/FEBRUARY 2020	4/2020	6906 3/3/2020	2,901.48
129578	99-10315	CINTAS CORPORATION NO.2	COVERALLS & GLOVES	4/2020	5016261679	760.90
129592	99-10315	CINTAS CORPORATION NO.2	CHEMICAL SPLASH GOGGLES	4/2020	9084759675	131.24
129555	99-10355	CIRCLE C CONSULTING LLC	20 CASES OF GLOVES	4/2020	2366	1,257.00
127465	99-10395	AUBREY WEATHERFORD	WEBSITE/FACEBOOK	4/2020	SAP0420	250.00
129223	99-10488	ADMIRAL EXPRESS LLC	PAPER TOWELS	4/2020	2095955	447.36
127454	99-10547	BEASLEY TECHNOLOGY INC	IT SERVICES/ANTI VIRUS	4/2020	COR-116809	92.50
128090	99-10547	BEASLEY TECHNOLOGY INC	MTHLY SEC/MONIT/STREET	4/2020	COR-116810	92.50
129829	99-10547	BEASLEY TECHNOLOGY INC	WIFI PART/ANNUAL	4/2020	COR-116843	50.00
129264	99-10555	WILLIAMS, JENNIFER	MEAL REIMB/JEN WILLIAMS	4/2020	2/4/2020 129264	14.00
127456	99-10695	ADVANCED COPIER SYSTEMS LLC	COPIER RENTAL	4/2020	IN9253	1,356.07
127279	99-10774	TIMOTHY CHRISTOPHER PENDLEY	YEARLY PEST CONTROL	4/2020	833015	232.50
129594	99-10941	BEAR COMMUNICATIONS INC	RADIO INSPECTION	4/2020	5010130	140.00
129216	99-10952	AMERICAN DOCUMENT SHREDDING	DOCUMENT SHREDDING	4/2020	106595	32.50
126197	99-1206	REASOR'S INC.	STUDY SESSION GROCERIES	4/2020	5406 3/16/20	16.16
128520	99-1206	REASOR'S INC.	FOOD FOR VALOR	4/2020	3812 3/16/2020	15.98
129273	99-1206	REASOR'S INC.	PRISONER FOOD	4/2020	3813 3/16/2020	312.60
127462A	99-133	INCOG	ANNUAL MEMBERSHIP	4/2020	223391	4,746.50
126934	99-161	CREEK COUNTY RURAL WATER	#4SEWER BILL/STATION 4	4/2020	741 3/27/2020	128.50
128920	99-175	STANDARD DISTRIBUTING INC	SANITIZER FOR COVID-19	4/2020	401798	176.79
129397	99-175	STANDARD DISTRIBUTING INC	84 CASES OF WATER	4/2020	401753	129.00
129556	99-175	STANDARD DISTRIBUTING INC	TP/HAND SOAP/SANITIZER	4/2020	400488	228.62
129880	99-175	STANDARD DISTRIBUTING INC	GLOVES FOR OFFICE STAFF	4/2020	402130	13.50
127496	99-2576	OKLAHOMA MUNICIPAL LEAGUE	ICERTIFICATION/PAM VANN	4/2020	2020 127496	68.50
128916	99-2576	OKLAHOMA MUNICIPAL LEAGUE	IADVERTISE/EMPLOYMENT	4/2020	075172	10.00
129062	99-2576	OKLAHOMA MUNICIPAL LEAGUE	IREQUIRED TRAINING/GUNN	4/2020	075110	85.00
129069	99-2576	OKLAHOMA MUNICIPAL LEAGUE	IREGISTRATION/BEYER	4/2020	075106	85.00
129787	99-3707	O'REILLY AUTOMOTIVE INC	CONTROL ARM/STRUTS	4/2020	153-221309	453.08
129789	99-3707	O'REILLY AUTOMOTIVE INC	BALL JOINT/BUSHINGS	4/2020	153-221471	80.82
129794	99-3707	O'REILLY AUTOMOTIVE INC	FUEL PUMP UNIT# 2719	4/2020	153-223248	130.98
129830	99-3822	TYLER TECHNOLOGIES, INC	FEES/ONLINE BILL PAY	4/2020	025-291829	7.50
127464A	99-4183	UPTOWN SAPULPA ACTION, INC.	ECONOMIC DEV SERVICES	4/2020	APR 2020 127464	2,500.00
127572	99-4269	CREEK COUNTY RURAL WTR #3	WATER AT THE RANGE	4/2020	33975 2/18/2020	24.00
129831	99-4700	COX COMMUNICATIONS	INTERNET/MARCH 2020	4/2020	1101 4/1/2020	8,012.57
129585	99-5046	GERALD L. PRICE	BATTERY	4/2020	16827	398.00
127011	99-6477	WEST PUBLISHING CORPORATION	INFO/DATABASE CHARGES	4/2020	842065172	578.97
129589	99-7044	SAPULPA DRIVE IN PHARMACY	IMUPIROCIN OINTMENT	4/2020	146629	56.00
129394	99-7868	WESTLAKE HARDWARE INC	EQUIPMENT MAINTENANCE	4/2020	8143151	120.85
129586	99-7868	WESTLAKE HARDWARE INC	VAR SUPPLIES/EQUIP MAINT	4/2020	8143171	171.38
129437	99-8016	NORTHERN SAFETY COMPANY	INSAFETY GLASSES	4/2020	903884497	134.46
129561	99-8059	ACE AIR, INC.	REPAIR HEAT BLOWER MOTOR	4/2020	106191	664.46
129577	99-8059	ACE AIR, INC.	THERMOSTAT STATION #3	4/2020	106409	128.27

FUND: 10 - GENERAL FUND

SUMMARY REPORT

P.O.#	VENDOR #	NAME	SUMMARY DESCRIPTION	DATE	INVOICE	AMOUNT
129124	99-8074	SPECIAL OPS UNIFORMS, INC	UNIFORMS FOR NEW HIRES	4/2020	793452	979.59
129679	99-8216	HILAND DAIRY FOODS CO.LLC	MILK FOR PRISONERS	4/2020	9065053	22.00
130002	99-8381	NEWEGG.COM	CABLE FOR NEW COMPUTER	4/2020	1302723685	25.52
130006	99-8381	NEWEGG.COM	SPEAKERS/HARD DRIVE	4/2020	1202855407	100.05
128608	99-8434	FLEETCOR TECHNOLOGIES d/b/aFUEL& OIL/MARCH 2020		4/2020	NP58034300	115.56
129788	99-8539	CROW BURLINGAME COMPANY	BATTERY/UNIT0599	4/2020	106-33779	110.16
129804	99-8630	CREEK COUNTY CLERK	FILING FEES	4/2020	3/31/20 129804	40.00
126866	99-8817	DE LAGE LANDEN PUBLIC FINANMTHLY COPIER LEASE		4/2020	67478223	2,327.00
126936	99-8817	DE LAGE LANDEN PUBLIC FINANKYOCERA PRINTER LEASE		4/2020	67471167	150.00
124449	99-8846	ARLEDGE & ASSOCIATES, P.C. AUDIT SERVICES FY 18/19		4/2020	31990	8,630.00
127497	99-9228	GOV'T FINANCE OFFICERS ASSOGFOA MEMBERSHIP DUES		4/2020	2020 127497	25.00
126865	99-9288	ADVANCE ALARMS, INC	MTHLY ALARM CHARGES	4/2020	1831920	25.00
128506	99-9288	ADVANCE ALARMS, INC	MTHLY ALARM MONITORING	4/2020	1835214	25.00
129432	99-9666	OKLAHOMA KENWORTH dba MHC KREAR BRAKES/LADDER 1		4/2020	R00483700203791	2,837.34
126937	99-9859	VERIZON WIRELESS SERVICES LWIRELESS CHARGES		4/2020	9851343085	800.20
FUND TOTAL:						52,038.52

FUND: 20 - SMA-AUTHORITY FUND

SUMMARY REPORT

129643	99-10074	CONTROL SYSTEM SOLUTIONS LCELL SRVC/4 LIFT STATIONS		4/2020	20008	1,675.00
127295	99-10143	PERDUE, BRANDON, FIELDER, CBAD DEBT COLLECTION		4/2020	3/1-3/31/2020	91.41
129754	99-10154	HAWKINS, INC	CHLORINE	4/2020	4691372	5,399.82
129791	99-10252	CECIL COX ENTERPRISES	2 TIRES/2008 DURANGO	4/2020	3057217	384.58
129832	99-103	ONG	ONG/FEBRUARY 2020	4/2020	6906 3/3/2020	2,463.44
127214	99-10302	LAMPTON WELDING SUPPLY CO, ACETYLENE GAS TANK RNTL		4/2020	949389	18.85
127338A	99-10302	LAMPTON WELDING SUPPLY CO, HELIUM & TANK RENTAL		4/2020	949390	30.20
129642	99-10302	LAMPTON WELDING SUPPLY CO, REPLACE CUTTING TORCH		4/2020	4956965	270.40
127465	99-10395	AUBREY WEATHERFORD	WEBSITE/FACEBOOK	4/2020	SAP0420	250.00
129631	99-10488	ADMIRAL EXPRESS LLC	SAFETY WEAR	4/2020	2090328-0	190.25
127454	99-10547	BEASLEY TECHNOLOGY INC	IT SERVICES/ANTI VIRUS	4/2020	COR-116809	92.50
128090	99-10547	BEASLEY TECHNOLOGY INC	MTHLY SEC/MONIT/STREET	4/2020	COR-116810	92.50
127289	99-10558	TECHNICAL PROGRAMMING SERVIYRLY PRNT/MAILING BILLS		4/2020	106048	1,866.02
129627	99-10567	JOSEPH LEWIS AUSSIEKER	CALIBRATION/FLOW METERS	4/2020	1420	400.00
127456	99-10695	ADVANCED COPIER SYSTEMS LLCCOPIER RENTAL		4/2020	IN9253	1,356.07
127279	99-10774	TIMOTHY CHRISTOPHER PENDLEYEARLY PEST CONTROL		4/2020	833015	232.50
127213	99-10838	WATER TECH INC	DE-WATER POLYMER	4/2020	86220	567.00
129303	99-10921	OKLAHOMA CHILLER CORPORATIOSENSOR REPLACEMENT		4/2020	W23956	794.91
129216	99-10952	AMERICAN DOCUMENT SHREDDINGDOCUMENT SHREDDING		4/2020	106595	32.50
127280	99-1112	WASTE MANAGEMENT OF OKLAHOMYEARLY REFUSE COLL		4/2020	2252348/2252858	56,709.94
129321	99-1443	BRENNTAG SOUTHWEST, INC.	ACH	4/2020	BSW196294	14,108.81
129644	99-175	STANDARD DISTRIBUTING INC	PPE GLOVES	4/2020	402131	28.60
126693	99-3593	CITY OF TULSA	POLSON SEWER CONSUMP	4/2020	21802 3/13/2020	477.56
127432	99-3593	CITY OF TULSA	METER CONNECT/USE FEE	4/2020	88966 3/23/2020	241.98
126692	99-3633	PUBLIC SERVICE COMPANY OF OSRWCS ELECTRIC SRVC		4/2020	59201 3/26/2020	4,523.66
129830	99-3822	TYLER TECHNOLOGIES, INC	FEES/ONLINE BILL PAY	4/2020	025-291829	352.50
127718A	99-3881	FHC, INC. DBA TETRA TECH FHENG SRVCS/SRWCS		4/2020	51576274	9,225.36
122085	99-4112	ACCURATE ENVIRONMENTAL INC.INFLU/EFFLUENT TESTING		4/2020	CC26012	3,020.00
127204	99-4112	ACCURATE ENVIRONMENTAL INC.DEQ TESTING		4/2020	CC30006	140.00
129314	99-4112	ACCURATE ENVIRONMENTAL INC.TOC FOR MARCH 2020		4/2020	CC19056	100.00
127339	99-5493	AQUARIUS ENTERPRISES INCORPWATER FOR LAB		4/2020	305890	13.00

FUND: 20 - SMA-AUTHORITY FUND

SUMMARY REPORT

P.O.#	VENDOR #	NAME	SUMMARY DESCRIPTION	DATE	INVOICE	AMOUNT
126869	99-7216	US CELLULAR	MTHLY CELL PHONE	4/2020	0365895757	25.28
126690	99-7994	BANCFIRST	DEBT SRVC/SMA UTIL BOND	4/2020	APR2020 126690	205,444.80
127425	99-7994	BANCFIRST	DEBT SERVICE PAYMENTS	4/2020	APR 2020 127425	136,491.66
128608	99-8434	FLEETCOR TECHNOLOGIES d/b/aFUEL& OIL/MARCH 2020		4/2020	NP58034300	131.14
129790	99-8539	CROW BURLLNGAME COMPANY	OIL/AIR FILTERS	4/2020	106-33824	76.00
127473	99-9207	S2 ENGINEERING SERVICES, PLIND PRETREATMENT SRVCS		4/2020	06-808	5,000.00
FUND TOTAL:						452,318.24

FUND: 29 - STORMWATER MANAGEMENT

SUMMARY REPORT

129832	99-103	ONG	ONG/FEBRUARY 2020	4/2020	6906 3/3/2020	432.85
128608	99-8434	FLEETCOR TECHNOLOGIES d/b/aFUEL& OIL/MARCH 2020		4/2020	NP58034300	142.63
FUND TOTAL:						575.48

FUND: 30 - STREET & ALLEY

SUMMARY REPORT

129832	99-103	ONG	ONG/FEBRUARY 2020	4/2020	6906 3/3/2020	258.65
129796	99-10873	BEST CHOICE AUTO GLASS LLC	WINDSHIELD/444H LOADER	4/2020	71950	200.00
129793	99-8539	CROW BURLLNGAME COMPANY	MISC. FILTERS	4/2020	106-34006	249.15
FUND TOTAL:						707.80

FUND: 31 - CEMETERY MAINTENANCE

SUMMARY REPORT

129832	99-103	ONG	ONG/FEBRUARY 2020	4/2020	6906 3/3/2020	374.02
129905	99-10302	LAMPTON WELDING SUPPLY CO,	ARGON/MIG WIRE/PLASMA	4/2020	04953422	278.00
129904	99-3707	O'REILLY AUTOMOTIVE INC	MISC EQUIP MAINTENANCE	4/2020	153-223750	9.27
127117	99-8372	SAWYER ENTERPRISES	MOWING	4/2020	300040820	1,600.00
128608	99-8434	FLEETCOR TECHNOLOGIES d/b/aFUEL& OIL/MARCH 2020		4/2020	NP58034300	20.76
FUND TOTAL:						2,282.05

FUND: 32 - HUNTING & FISHING

SUMMARY REPORT

126823	99-10516	HINSCH MARY	CARETAKER COMMISSION	4/2020	836710	115.00
126824	99-10516	HINSCH MARY	CARETAKER STIPEND	4/2020	APR 2020 126824	750.00
127438	99-68	A & M ELECTRIC, INC	ELECTRIC REPAIR @CAMPSITE	4/2020	7429	97.00
129956	99-68	A & M ELECTRIC, INC	BREAKER REPAIR	4/2020	7402	90.75
FUND TOTAL:						1,052.75

FUND: 33 - GOLF COURSE

SUMMARY REPORT

129470	99-10133	HARRELL'S LLC	PRE-EMERGENTS/GREENS	4/2020	INV01354344	2,750.00
129832	99-103	ONG	ONG/FEBRUARY 2020	4/2020	6906 3/3/2020	354.72
128000	99-4700	COX COMMUNICATIONS	BLANKET-TV'S & GRILL	4/2020	67801 3/30/2020	36.90
129461	99-9734	TERRY SISCO dba SISCO TURF	AERATE GREENS	4/2020	3/25/20 129461	2,250.00
FUND TOTAL:						5,391.62

FUND: 34 - LIBRARY

SUMMARY REPORT

127049	99-10095	RICOH USA, INC	WARRANTY RENEWAL	4/2020	5059175163	186.68
129832	99-103	ONG	ONG/FEBRUARY 2020	4/2020	6906 3/3/2020	441.34

FUND: 34 - LIBRARY

SUMMARY REPORT

P.O.#	VENDOR #	NAME	SUMMARY DESCRIPTION	DATE	INVOICE	AMOUNT
128455	99-10904	SENTRY CUSTOM SECURITY INC	ADDITION TO SEC GATES	4/2020	SAPU100	6,195.00
127045	99-7963	TAMMY YVONNE TALLEY	JANITORIAL SERVICES	4/2020	APR 2020 127045	345.00
127046	99-7963	TAMMY YVONNE TALLEY	JANITORIAL SERVICES	4/2020	APR 2020 127046	950.00
129719	99-8769	OKLAHOMA DEPARTMENT OF LABOBOILER INSPECTION		4/2020	B843273	25.00
FUND TOTAL:						8,143.02

FUND: 35 - PARKS & RECREATION

SUMMARY REPORT

129661	99-10160	MERRIFIELD OFFICE SOLUTIONS	COFFEE/TEA BREWER	4/2020	189992-001	1,539.99
129674	99-10160	MERRIFIELD OFFICE SOLUTIONS	GREETING/THANKS CARDS	4/2020	190877-001	85.00
129832	99-103	ONG	ONG/FEBRUARY 2020	4/2020	6906 3/3/2020	850.65
129660	99-10803	SIGN IT INC	SIGN FOR KELLYLANE PARK	4/2020	46461	60.00
127623	99-4700	COX COMMUNICATIONS	CABLE/BTW& SENIOR CTR	4/2020	88013/30/2020	7.37
128608	99-8434	FLEETCOR TECHNOLOGIES d/b/a	FUEL& OIL/MARCH 2020	4/2020	NP58034300	91.29
127390A	99-8545	TITAN COMMERCIAL SERVICES,	CLEAN/SEC PARK RSTRMS	4/2020	APR 2020 127390	750.00
129668	99-9143	THE PROPHET CORPORATION dba	HAND WEIGHTS	4/2020	9706135	26.45
127395	99-9288	ADVANCE ALARMS, INC	ALARM MONITORING	4/2020	1831513	50.00
FUND TOTAL:						3,460.75

FUND: 36 - SWIMMING POOL

SUMMARY REPORT

129832	99-103	ONG	ONG/FEBRUARY 2020	4/2020	6906 3/3/2020	28.29
127397	99-9288	ADVANCE ALARMS, INC	ALARM MONITORING	4/2020	1831246	25.00
127437	99-9370	OKLAHOMA STATE DEPARTMENT	OBATH/FOOD SRVC PERMITS	4/2020	19-79286	125.00
FUND TOTAL:						178.29

FUND: 40 - FIRE CASH

SUMMARY REPORT

129587	99-10941	BEAR COMMUNICATIONS INC	BATTERIES/HANDHELD RAD	4/2020	5005631	587.10
129584	99-9336	ULINE, INC.	IBC TANK/DISINFECTANT	4/2020	118709027	654.82
FUND TOTAL:						1,241.92

FUND: 44 - MAJOR THOROFARE

SUMMARY REPORT

126873A	99-2507	SIGNALTEK, INC	STREET SIGNAL REPAIRS	4/2020	17352	750.00
127177	99-2507	SIGNALTEK, INC	TRAFFIC LIGHT CALLOUTS	4/2020	220915	1,585.31
128681	99-2507	SIGNALTEK, INC	LIGHT REPAIR/MISS & JAMES	4/2020	220902	4,750.00
129728	99-2507	SIGNALTEK, INC	TRAFFIC CONTROL ASSEMB	4/2020	220917	17,950.00
126691	99-3633	PUBLIC SERVICE COMPANY OF	OEXPRESSWAY LIGHTS	4/2020	86207 3/31/2020	196.12
FUND TOTAL:						25,231.43

FUND: 45 - CAPITAL IMPROVEMENTS

SUMMARY REPORT

126695	99-1850	AMERICAN HERITAGE BANK	QRTLY DEBT PAYMENTS	4/2020	4TH QTR 126695	11,696.09
FUND TOTAL:						11,696.09

FUND: 46 - WATER & SEWER SALES TAX

SUMMARY REPORT

129832	99-103	ONG	ONG/FEBRUARY 2020	4/2020	6906 3/3/2020	425.01
127896	99-3321	CENTRAL TECH	CMOM SAFETY CLASSES	4/2020	9267	80.00

FUND: 46 - WATER & SEWER SALES TAX

SUMMARY REPORT

P.O.#	VENDOR #	NAME	SUMMARY DESCRIPTION	DATE	INVOICE	AMOUNT
128608	99-8434	FLEETCOR TECHNOLOGIES	d/b/a FUEL & OIL/MARCH 2020	4/2020	NP58034300	28.07
129850	99-8861	NATHAN CHADWICK	GRADE & SOD/W GORDON	4/2020	4376	1,500.00
FUND TOTAL:						2,033.08
FUND: 47 - VAC/SPAY/NEUTR ESCRW FUND						SUMMARY REPORT
129677	99-8803	SPAY OKLAHOMA, INC	SPAY/NEUTER FEES	4/2020	MAR2020	410.00
FUND TOTAL:						410.00
FUND: 48 - WATER RESOURCE						SUMMARY REPORT
129503	99-4895	BADGER METER INC.	50 METERS	4/2020	1355648	8,490.71
FUND TOTAL:						8,490.71
FUND: 49 - SEWER EXT & DEV FUND						SUMMARY REPORT
123678A	99-3881	FHC, INC. DBA TETRA TECH	FHFRK RD SANI SEWER EXT	4/2020	51576301	3,500.00
123969R	99-3881	FHC, INC. DBA TETRA TECH	FHWTP ENGINEERING SRVC	4/2020	51577118	25,500.00
FUND TOTAL:						29,000.00
FUND: 57 - E-911 FUND						SUMMARY REPORT
127536A	99-4319	AT&T	E-911 CHARGES	4/2020	6585 4/1/2020	236.90
FUND TOTAL:						236.90
FUND: 58 - JUVENILE JUSTICE FUND						SUMMARY REPORT
127458	99-7564	HUMAN SKILLS & RESOURCES	I PROBATION SERVICES	4/2020	3/1-3/31/2020	1,250.00
127459	99-7564	HUMAN SKILLS & RESOURCES	IDRUG TESTING/COUNSEL	4/2020	4/2020 127459	45.00
FUND TOTAL:						1,295.00
FUND: 60 - GRANTS AND AID						SUMMARY REPORT
129528	99-10159	LAWRENCE COUNTY NEWSPAPERS,	ADVERTISE FOR BIDS	4/2020	24208	219.20
129527	99-10593	OMEGA RAIL MANAGEMENT INC	RR CROSSING PERMIT APP	4/2020	1/6/2020 129527	1,250.00
122072A	99-3881	FHC, INC. DBA TETRA TECH	FHWESTSIDE SEWER/SENEGE	4/2020	51576300	20,500.00
129358	99-4022	OKLAHOMA STATE UNIVERSITY	VEH RESC TECH 1B CLASS	4/2020	076246	6,500.00
129360	99-4022	OKLAHOMA STATE UNIVERSITY	STRUC COLL OPER CLASS	4/2020	076230	28,000.00
FUND TOTAL:						56,469.20
FUND: 65 - STREET IMP.SALES TAX						SUMMARY REPORT
127426	99-7994	BANCFIRST	DEBT SERVICE PAYMENTS	4/2020	APR 2020 127426	52,102.29
FUND TOTAL:						52,102.29
FUND: 81 - G.O. BOND SINKING FUND						SUMMARY REPORT
126698	99-9620	UMB, CORPORATE TRUST DEPT.	DEBT SERVICE PAYMENTS	4/2020	4/2/2020 126698	239,100.00
FUND TOTAL:						239,100.00
GRAND TOTAL:						953,455.14

G / L R E C A P

PERIOD	G/L	ACCOUNT	NAME	AMOUNT	TOTAL
4/2020	10	501-301	TRAINING & TRAVEL	186.16	
4/2020	10	501-302	DUES AND SUBSCRIPTIONS	4,746.50	
4/2020	10	501-311	PROFESSIONAL SERVICES	2,500.00	
4/2020	10	503-201	OFFICE SUPPLIES	13.50	
4/2020	10	504-315	FEES & OTHER CHARGES	40.00	
4/2020	10	504-407	BOOKS	578.97	
4/2020	10	505-302	DUES AND SUBSCRIPTONS	25.00	
4/2020	10	506-301E	EMPLOYEE TRAINING/RECOGNITION	176.79	
4/2020	10	506-312	ADVERTISING	10.00	
4/2020	10	508-315	FEES & OTHER CHARGES	25.00	
4/2020	10	508-331	UTILITIES	215.83	
4/2020	10	509-302	DUES & SUBSCRIPTIONS	68.50	
4/2020	10	509-311	PROFESSIONAL SERVICES	8,630.00	
4/2020	10	510-311	PROFESSIONAL SERVICES	6,549.66	
4/2020	10	510-315	FEES & OTHER CHARGES	7.50	
4/2020	10	511-201	OFFICE SUPPLIES	53.52	
4/2020	10	511-211	JANITORIAL SUPPLIES	260.61	
4/2020	10	511-214	OPERATIONAL SUPPLIES	129.00	
4/2020	10	511-214E	EMS SUPPLIES	2,205.14	
4/2020	10	511-221	FUEL AND OIL	81.12	
4/2020	10	511-241	SAFETY EQUIPMENT	134.46	
4/2020	10	511-331	UTILITIES	1,697.92	
4/2020	10	511-332	COMMUNICATIONS	800.20	
4/2020	10	511-351	MAINTENANCE-EQUIPMENT	292.23	
4/2020	10	511-352	MAINTENANCE-VEHICLES	3,375.34	
4/2020	10	511-353	MAINT-BUILDINGS & FIXTURE	792.73	
4/2020	10	511-505	LEASE PAYMENTS	150.00	
4/2020	10	512-211	JANITORIAL SUPPLIES	272.21	
4/2020	10	512-214	OPERATIONAL SUPPLIES	141.55	
4/2020	10	512-221	FUEL AND OIL	34.44	
4/2020	10	512-301	TRAINING AND TRAVEL	14.00	
4/2020	10	512-314	UNIFORM CLEANING	979.59	
4/2020	10	512-321	PRISONER CARE	334.60	
4/2020	10	512-331	UTILITIES	694.45	
4/2020	10	512-352	MAINTENANCE-VEHICLES	834.99	
4/2020	10	513-313	PRINTING	70.40	
4/2020	10	513-331	UTILITIES	338.88	
4/2020	10	513-351	MAINT - EQUIPMENT	25.00	
4/2020	10	590-141	CONTRACT LABOR	185.00	
4/2020	10	590-211	JANITOR SUPPLIES	447.36	
4/2020	10	590-311	PROFESSIONAL SERVICES	250.00	
4/2020	10	590-312	ADVERTISING	85.35	
4/2020	10	590-315	FEES & OTHER CHARGES	32.50	
4/2020	10	590-331	UTILITIES	106.90	

G / L R E C A P

PERIOD	G/L	ACCOUNT	NAME	AMOUNT	TOTAL
4/2020	10	590-332	COMMUNICATIONS	9,480.05	
4/2020	10	590-351	MAINTENANCE-EQUIPMENT	1,406.07	
4/2020	10	590-353	MAINT-BUILDING & FIXTURES	232.50	
4/2020	10	590-505	LEASE PAYMENTS	2,327.00	52,038.52
4/2020	20	523-221	FUEL AND OIL	43.65	
4/2020	20	523-311	PROFESSIONAL SERVICES	1,957.43	
4/2020	20	523-315	OTHER FEES & CHARGES	352.50	
4/2020	20	523-352	MAINTENANCE-VEHICLES	460.58	
4/2020	20	524-212	CHEMICALS	19,508.63	
4/2020	20	524-214	OPERATIONAL SUPPLIES	30.20	
4/2020	20	524-221	FUEL & OIL	39.93	
4/2020	20	524-311	PROFESSIONAL SERVICES	100.00	
4/2020	20	524-315B	FEES & OTHR CHGS-SKIATOOK	9,225.36	
4/2020	20	524-322	WATER PURCHASE	241.98	
4/2020	20	524-331	UTILITIES	6,273.27	
4/2020	20	524-341	RENTAL OF EQUIPMENT	13.00	
4/2020	20	524-354	MAINTENANCE-FACILITIES	794.91	
4/2020	20	525-212	CHEMICALS	567.00	
4/2020	20	525-221	FUEL & OIL	47.56	
4/2020	20	525-231	MINOR TOOLS	270.40	
4/2020	20	525-241	SAFETY SUPPLIES	218.85	
4/2020	20	525-311	PROFESSIONAL SERVICES	400.00	
4/2020	20	525-311D	PROF SERVICES-TESTING	140.00	
4/2020	20	525-325	SEWAGE DISPOSAL FEE	477.56	
4/2020	20	525-331	UTILITIES	606.92	
4/2020	20	525-332	COMMUNICATIONS	1,700.28	
4/2020	20	525-341	RENTAL OF EQUIPMENT	18.85	
4/2020	20	527-141	CONTRACT LABOR	56,709.94	
4/2020	20	528-141	CONTRACT LABOR	5,000.00	
4/2020	20	528-311D	PROFESSIONAL SERV - TESTING	3,020.00	
4/2020	20	590-141	CONTRACT LABOR	185.00	
4/2020	20	590-311	PROFESSIONAL SERVICES	250.00	
4/2020	20	590-315	OTHER FEES & CHARGES	32.50	
4/2020	20	590-331	UTILITIES	106.91	
4/2020	20	590-351	EQUIPMENT MAINTENANCE	1,356.07	
4/2020	20	590-353	BUILDING MAINTENANCE	232.50	
4/2020	20	590-501F	BOND EXP - SERIES 2012	135,866.66	
4/2020	20	590-501G	REVENUE BOND EXP - SERIES 2013	205,444.80	
4/2020	20	590-502	REVENUE BOND TRUSTEE FEES	625.00	452,318.24
4/2020	29	529-221	FUEL & OIL	142.63	
4/2020	29	529-331	UTILITIES	432.85	575.48
4/2020	30	530-331	UTILITIES	258.65	

G / L R E C A P

PERIOD	G/L	ACCOUNT	NAME	AMOUNT	TOTAL
4/2020	30	530-351	MAINTENANCE-EQUIPMENT	449.15	707.80
4/2020	31	531-141	CONTRACT LABOR	1,600.00	
4/2020	31	531-214	OPERATING SUPPLIES	278.00	
4/2020	31	531-221	FUEL & OIL	20.76	
4/2020	31	531-331	UTILITIES	374.02	
4/2020	31	531-351	MAINTENANCE-EQUIPMENT	9.27	2,282.05
4/2020	32	532-141	CONTRACT LABOR	750.00	
4/2020	32	532-142	PERMIT SALES COMMISSION	115.00	
4/2020	32	532-351	MAINTENANCE-EQUIPMENT	90.75	
4/2020	32	532-354	MAINTENANCE-FACILITIES	97.00	1,052.75
4/2020	33	533-212	CHEMICALS	2,750.00	
4/2020	33	533-331	UTILITIES	354.72	
4/2020	33	533-354	MAINTENANCE-FACILITIES	2,286.90	5,391.62
4/2020	34	534-141	CONTRACT LABOR	1,295.00	
4/2020	34	534-302	DUES AND SUBSCRIPTIONS	186.68	
4/2020	34	534-331	UTILITIES	441.34	
4/2020	34	534-351	MAINTENANCE-EQUIPMENT	6,220.00	8,143.02
4/2020	35	535-141	CONTRACT LABOR	750.00	
4/2020	35	535-221	FUEL AND OIL	91.29	
4/2020	35	535-243	RECREATIONAL SUPPLIES	26.45	
4/2020	35	535-260	MINOR EQUIPMENT & FURNISHINGS	1,539.99	
4/2020	35	535-313	PRINTING	145.00	
4/2020	35	535-331	UTILITIES	850.65	
4/2020	35	535-332	COMMUNICATIONS	7.37	
4/2020	35	535-351	MAINTENANCE-EQUIPMENT	50.00	3,460.75
4/2020	36	536-302	DUES & SUBSCRIPTIONS	125.00	
4/2020	36	536-331	UTILITIES	28.29	
4/2020	36	536-351	MAINTENANCE-EQUIPMENT	25.00	178.29
4/2020	40	540-401	EQUIPMENT	1,241.92	1,241.92
4/2020	44	544-331	UTILITIES	196.12	
4/2020	44	544-354	MAINTENANCE-FACILITIES	25,035.31	25,231.43
4/2020	45	533-501C	NOTE PAYMENTS	11,696.09	11,696.09
4/2020	46	546-221	FUEL AND OIL	28.07	
4/2020	46	546-301	TRAINING AND TRAVEL	80.00	
4/2020	46	546-331	UTILITIES	425.01	

G / L R E C A P

PERIOD	G/L	ACCOUNT	NAME	AMOUNT	TOTAL
4/2020	46	546-354	MAINTENANCE-FACILITIES	1,500.00	2,033.08
4/2020	47	547-315	OTHER SERVICES & CHARGES	410.00	410.00
4/2020	48	1699	INVENTORY PURCHASED	8,490.71	8,490.71
4/2020	49	525-311	PROFESSIONAL SERVICES	25,500.00	
4/2020	49	526-311	PROFESSIONAL SERVICES	3,500.00	29,000.00
4/2020	57	557-315-.01	FEES & OTHER CHARGES-WIRELESS	236.90	236.90
4/2020	58	558-141	CONTRACT LABOR	1,250.00	
4/2020	58	558-311	PROFESSIONAL SERVICES	45.00	1,295.00
4/2020	60	561-410P.22	FACILITIES-CONTRACT 2018-2019	219.20	
4/2020	60	585-301	TRAINING & TRAVEL	34,500.00	
4/2020	60	592-311A	PROF SVCS - DESGN & BID	20,500.00	
4/2020	60	592-405B	FACILITIES - CONTRACT	1,250.00	56,469.20
4/2020	65	565-501	BOND EXP -SERIES 2004/2014	39,583.34	
4/2020	65	565-501I	2004/2014 DEBT SERVICE - INT	12,185.61	
4/2020	65	565-502	REVENUE BOND TRUSTEE FEES	333.34	52,102.29
4/2020	81	581-501I	G.O. BOND INTEREST	39,100.00	
4/2020	81	581-501P	G.O. BOND PRINCIPAL	200,000.00	239,100.00
			GRAND TOTAL ESTIMATE:		0.00
			GRAND TOTAL ACTUAL:		953,455.14
			REPORT TOTAL:		953,455.14



Consent Agenda 8. B.

City Council Regular

Meeting Date: April 20, 2020

Submitted For: Hailey Sharp, Accounts Payable Clerk

Submitted By: Amber Fisher, Accounts Payable Clerk

SUBJECT:

Consider approving prepaid claims in the amount of \$2,136.84

Attachments

Pre-paid Claims 4/20/2020

Prepaid Claims for Agenda 04/20/2020
Submitted by: Hailey Sharp A/P

City:

Martha Stalker Reimbursement for PLA Conference- \$2,136.84
SMA:

Total Amount \$ 2,136.84



AGENDA ITEM

Administration 11. A.

City Council Regular

Meeting Date: April 20, 2020

Submitted By: Pam Vann, Finance Director

Department: Finance

Presented By: Pam Vann

SUBJECT:

Discussion and possible action regarding a Resolution of the City of Sapulpa, Oklahoma and the Sapulpa Municipal Authority amending the FY 2019-2020 annual budget by increasing revenue and appropriations in the Stormwater Management Fund in the amount of \$11,385.00 to recognize reimbursements for damage to the sewer vac truck.

BACKGROUND:

The City has received an insurance reimbursement in the amount of \$11,385.00 for damage to the sewer vac truck used by the stormwater department. Appropriations need to be made to cover the costs of the repairs.

RECOMMENDATION:

Staff recommends approval of the resolution.

Attachments

Stormwater Management Fund Resolution-Reimbursement

Stormwater Management Fund budget adjustment

RESOLUTION NO. _____

A RESOLUTION OF THE CITY OF SAPULPA, OKLAHOMA AND THE SAPULPA MUNICIPAL AUTHORITY AMENDING THE FY 2019-2020 ANNUAL BUDGET BY INCREASING REVENUE AND APPROPRIATIONS IN THE STORMWATER MANAGEMENT FUND IN THE AMOUNT OF \$11,385.00 TO RECOGNIZE REIMBURSEMENTS FOR DAMAGE TO THE SEWER VAC TRUCK.

WHEREAS, the City of Sapulpa has received \$11,385.00 for reimbursements for damage done to the sewer vac truck; and

WHEREAS, appropriations need to be made to cover the repair costs,

NOW, THEREFORE BE IT RESOLVED, by the City Council of the City of Sapulpa, Oklahoma, and the Sapulpa Municipal Authority, Sapulpa, Oklahoma, that the following budget amendment be made:

WATER AND SEWER IMPROVEMENT SALES TAX

(Increase)	29-4086 Reimbursements	<u>\$11,385.00</u>
	Total Revenue Increase:	\$11,385.00
(Increase)	29-529-352 Maintenance-Vehicles	<u>\$11,385.00</u>
	Total Appropriations Increase:	\$11,385.00

PASSED BY THE CITY COUNCIL FOR THE CITY OF SAPULPA, OKLAHOMA, AND THE SAPULPA MUNICIPAL AUTHORITY, SAPULPA, and signed by the Mayor/Chairman this 20th day of April 2020.

Lou Martin, Mayor Pro Tem/Chairman

ATTEST:

Shirley Burzio, City Clerk/Trust Secretary

David Widdoes, City Attorney/Trust Attorney

BUDGET TRANSFER REQUEST

DEPARTMENT	Department Head Signature	Date Requested
stormwater management		4/20/2020

to recognize reimbursement revenue and appropriate for repairs made
to vac truck

RESOLUTION #

Account #	Account Name	Amount Budgeted	Amount of Increase	Amount of Decrease	Adjusted Budget
29-4086	Reimbursements	\$0	\$11,385		\$11,385
29-529-352	Maintenance-Facilities	\$45,245	\$11,385		\$56,630

Date Approved	Finance Director	Date Rejected	Reason
Date Approved	City Manager	Date Rejected	Reason

FY 19-20	Transfer #: 19-
-----------------	------------------------



AGENDA ITEM

Administration 11. B.

City Council Regular

Meeting Date: April 20, 2020

Submitted By: Pam Vann, Finance Director

Department: Finance

Presented By: Pam Vann

SUBJECT:

Discussion and possible action regarding Resolution of the City of Sapulpa, Oklahoma and the Sapulpa Municipal Authority amending the FY 2019-2020 annual budget by increasing revenue and appropriations in the Water and Sewer Sales Tax Fund in the amount of \$3,900.00 to recognize reimbursements for damage to a fire hydrant.

BACKGROUND:

The City has received a reimbursement in the amount of \$3,900.00 for damage to a fire hydrant at 117 North Division. An appropriation needs to be made to cover the costs of the repair.

RECOMMENDATION:

Staff recommends approval of this resolution.

Attachments

Water & Sewer Improvements Sales Tax Resolution-Reimbursements

Water & Sewer Improvement Sales Tax Fund budget adjustment

RESOLUTION NO. _____

A RESOLUTION OF THE CITY OF SAPULPA, OKLAHOMA AND THE SAPULPA MUNICIPAL AUTHORITY AMENDING THE FY 2019-2020 ANNUAL BUDGET BY INCREASING REVENUE AND APPROPRIATIONS IN THE WATER AND SEWER IMPROVEMENT SALES TAX FUND IN THE AMOUNT OF \$3,900.00 TO RECOGNIZE REIMBURSEMENTS FOR DAMAGE TO A FIRE HYDRANT.

WHEREAS, the City of Sapulpa has received \$3,900.00 for reimbursements for damage done to a fire hydrant at 117 North Division; and

WHEREAS, appropriations need to be made to cover the repair costs,

NOW, THEREFORE BE IT RESOLVED, by the City Council of the City of Sapulpa, Oklahoma, and the Sapulpa Municipal Authority, Sapulpa, Oklahoma, that the following budget amendment be made:

WATER AND SEWER IMPROVEMENT SALES TAX

(Increase)	46-4086 Reimbursements	<u>\$3,900.00</u>
	Total Revenue Increase:	\$3,900.00
(Increase)	46-546-354 Facilities	<u>\$3,900.00</u>
	Total Appropriation Increase:	\$3,900.00

PASSED BY THE CITY COUNCIL FOR THE CITY OF SAPULPA, OKLAHOMA, AND THE SAPULPA MUNICIPAL AUTHORITY, SAPULPA, and signed by the Mayor/Chairman this 20th day of April 2020.

Lou Martin, Mayor Pro Tem/Chairman

ATTEST:

Shirley Burzio, City Clerk/Trust Secretary

David Widdoes, City Attorney/Trust Attorney

BUDGET TRANSFER REQUEST

DEPARTMENT	Department Head Signature	Date Requested
-------------------	----------------------------------	-----------------------

W&S SALES TAX		4/20/2020
---------------	--	-----------

to recognize reimbursement revenue and appropriate for repairs made

to fire hydrant

RESOLUTION #

Account #	Account Name	Amount Budgeted	Amount of Increase	Amount of Decrease	Adjusted Budget
46-4086	Reimbursements	\$9,284	\$3,900		\$13,184
46-546-354	Maintenance-Facilities	\$227,610	\$3,900		\$231,510

Date Approved	Finance Director	Date Rejected	Reason
----------------------	-------------------------	----------------------	---------------

--	--	--	--

Date Approved	City Manager	Date Rejected	Reason
----------------------	---------------------	----------------------	---------------

--	--	--	--

FY 19-20

Transfer #: 19-



AGENDA ITEM

Administration 11. C.

City Council Regular

Meeting Date: April 20, 2020

Submitted For: David Widdoes, City Attorney

Submitted By: Amy Hoehner, Legal Assistant

Department: Legal

Presented By: David Widdoes

SUBJECT:

Discussion and possible action regarding approval of a straight line of credit ("SLOC") from American Heritage Bank for \$550,000.00 to provide interim short-term funding for 2020 GO bond projects, and authorization for the City Manager to execute all necessary and related documentation.

BACKGROUND:

On April 6, 2020, the City Council, by Resolution Nos. 4620 and 4621, authorized and approved the sale of 15,000,000.00 GO Bonds to occur on May 4, 2020. The City will receive the bond sale proceeds no later than June 28, 2020. To enable the City to start certain bonded projects now, AHB has agreed to issue a SLOC to provide and satisfy the fund availability requirement in the interim. The SLOC will, if approved, allow the City to start and implement the HVAC repair/improvement at the police station and enter into a contract to begin the downtown master plan project. It is critical that both these projects start now. Since the bond sale proceeds will be available before the SLOC maturity date, there is no cost to the City unless it actually draws funds down on the SLOC.

RECOMMENDATION:

Staff recommends Council approve the Straight Line of Credit and authorize the City Manager to execute all documentation as stated.



AGENDA ITEM

Administration 11. D.

City Council Regular

Meeting Date: April 20, 2020

Submitted By: Pam Vann, Finance Director

Department: Finance

Presented By: Pam Vann

SUBJECT:

Discussion and possible action regarding a Resolution of the City of Sapulpa, Oklahoma amending the FY 2019-2020 annual budget by increasing revenue and appropriations in the GO Bond Construction Fund to recognize proceeds from a Line of Credit issued by American Heritage Bank in the amount of \$550,000.00 for interim short-term funding for projects.

BACKGROUND:

In a separate agenda item the Council is presented with a Line of Credit from American Heritage Bank for short-term financing of bond projects. The City will receive proceeds from the sale of \$15,000,000.00 Go Bonds no later than June 28, 2020. Two of the projects, the HVAC system for the police station and the downtown master plan, need to be started as soon as possible. This Line of Credit will enable the City to award the contracts for these projects prior to receipt of the bond proceeds.

RECOMMENDATION:

Staff recommends approval of this resolution.

Attachments

GO Bond Construction Fund Resolution

Go Bond Construction Fund budget adjustment

RESOLUTION NO. _____

A RESOLUTION OF THE CITY OF SAPULPA, OKLAHOMA AMENDING THE FY 2019-2020 ANNUAL BUDGET BY INCREASING REVENUE AND APPROPRIATIONS IN THE GO BOND CONSTRUCTION FUND TO RECOGNIZE PROCEEDS FROM A LINE OF CREDIT ISSUED BY AMERICAN HERITAGE BANK IN THE AMOUNT OF \$550,000.00 FOR INTERIM SHORT-TERM FUNDING FOR PROJECTS.

WHEREAS, the City of Sapulpa has a Line of Credit from American Heritage Bank in the amount of \$550,000.00 for short-term funding for the 2020 GO Bond Projects; and

WHEREAS, the City will receive proceeds from the sale of \$15,000,000.00 GO Bonds no later than June 28, 2020; and

WHEREAS, it is critical for the HVAC improvements and the downtown master plan be started prior to receipt of the bond proceeds; and

WHEREAS, the Line of Credit will enable the City to start the two projects and if necessary, draw funds prior to receipt of the bond proceeds,

NOW, THEREFORE BE IT RESOLVED, by the City Council of the City of Sapulpa, Oklahoma, that the following budget amendment be made:

GO BOND CONSTRUCTION FUND

(Increase)	83-4203 Loan Proceeds	<u>\$550,000.00</u>
	Total Revenue Increase:	\$550,000.00

POLICE STATION

(Increase)	83-592-404 Building & Fixtures	<u>\$260,000.00</u>
	Total Appropriations Increase:	\$260,000.00

DOWNTOWN MASTER PLAN

(Increase)	83-580-311 Professional Services	<u>\$200,000.00</u>
	Total Appropriations Increase:	\$200,000.00

NON-DEPARTMENTAL

(Increase)	83-590-390 Contingency	<u>\$ 90,000.00</u>
	Total Appropriations Increase:	\$ 90,000.00

PASSED BY THE CITY COUNCIL FOR THE CITY OF SAPULPA,
OKLAHOMA, and signed by the Mayor this 20th day of April 2020.

Lou Martin, Mayor Pro Tem

ATTEST:

Shirley Burzio, City Clerk

David Widdoes, City Attorney

BUDGET TRANSFER REQUEST

DEPARTMENT	Department Head Signature	Date Requested
GO BOND CONSTR		4/20/2020

TO RECOGNIZE LINE OF CREDIT PROCEEDS TO PROVIDE FOR
 APPROPRIATIONS FOR THE HVAC SYSTEM AND THE DOWNTOWN MASTER PLAN

RESOLUTION #

Account #	Account Name	Amount Budgeted	Amount of Increase	Amount of Decrease	Adjusted Budget
83-4203	LOAN PROCEEDS	\$0	\$550,000		\$550,000
83-592-404	BUILDING & FIXTURES	\$0	\$260,000		\$260,000
83-580-311	PROFESSIONAL SERVICES	\$0	\$200,000		\$200,000
83-590-390	CONTINGENCY	\$0	\$90,000		\$90,000

Date Approved	Finance Director	Date Rejected	Reason

Date Approved	City Manager	Date Rejected	Reason

FY 19-20		Transfer #:	19-
-----------------	--	--------------------	------------



AGENDA ITEM

Administration 11. E.

City Council Regular

Meeting Date: April 20, 2020

Submitted For: Pete Sellers, Police Chief

Submitted By: Chris Jeffries, Police Department Admin.

Department: Police Department

Presented By: Pete Sellers

SUBJECT:

Discussion and possible action regarding award of Bid No. COS-10079 for the Replacement of Roof Top HVAC Units (Sapulpa Police Department) Project, as follows: (i) rejecting apparent low bid of \$254,480.00 from Air Conditioning Service Inc., for failure to meet bid specifications, and (ii) awarding bid to Powers Mechanical Service, as being the lowest, responsive and responsible bidder, in the amount of \$256,530.11, and authorize the Mayor/Chairman to execute all contract documents related thereto.

BACKGROUND:

Six (6) bid packets were received and opened on Wednesday, March 25, 2020. Upon initial review, it was apparent that two bids required further analysis: the apparent low bid from Air Conditioning Service, Inc. for \$254,480.00, and the next low bid from Powers Mechanical Service for \$256,530.11. Accordingly, on April 2, 2020, staff requested a detailed listing of equipment from both bidders to review and compare against the bid specification requirements. Both bidders responded and submitted additional information by return email. After careful review and comparison of these responses, staff was able to determine that only the bid from Powers Equipment met all specifications and requirements. As such, the apparent low bid from Air Conditioning service should be rejected and the bid awarded to Powers Mechanical Service as the lowest, responsive and responsible bid.

RECOMMENDATION:

Staff recommends rejection and award of the bids as stated.

Fiscal Impact

Amount: \$256,530.11

To be paid from: GO Bond Construction Fund

Account number: 83-592-404

Attachments

Bid Tabulations

Mechanical Service Company, dba Powers

BID RESULTS FOR BID # C0510079

DATE 3/25/2020

TIME 2:00 pm

387,359	316,232	344,550	254,480	260,422
GOBER	Donah Services	BMS 4182,900 415,650	Airconditioning Services	Air Comfort Inc.

256,530.4				
Powers				

Pete Sellers

From: Shawn Shoemaker [sshoe-maker@powersar.com]
Sent: Thursday, April 02, 2020 8:27 AM
To: psellers@sapulpapolice.com
Cc: 'Shell Kincheloe'; Chad Ketcher
Subject: FW: Sapulpa job
Attachments: Sapulpa Police Department_Aaon RTU Submittal Data.pdf;
AM036FXMDCH+AA+Submittal_DVM+S+Eco_04022019.pdf;
AM036JNCDC+AA+SUBMITTAL_CEILING_04092019.pdf

These are the submittals for the AAON RTU and AAON Makeup Air Unit, & The mini split. We are also providing an 2 Exhaust Fan and OSA (Outside Air Louvers) Louvers as well. Chad Ketcher can provide a scope or submittals for controls if you need that as well. Thanks for this opportunity looking forward to working with you and your team to resolve your issues. Please let me know if there is anything else you need to help with this process.

Shawn Shoemaker

Service Manager Oklahoma Mechanical



Powers – Mechanical Service Company

Cell 918-340-4768

sshoe-maker@powersar.com | www.powersar.com



From: Chad Fisher <cfisher@powersar.com>
Sent: Thursday, April 2, 2020 7:38 AM
To: Shawn Shoemaker <sshoe-maker@powersar.com>; Christopher Lomax <clomax@powersar.com>; David Squires <DSquires@powersar.com>
Cc: Chase Ransom <cransom@powersar.com>
Subject: RE: Sapulpa job

10 week lead time from time of order. As of Yesterday there was no issue with the virus causing issues with the lead time.

Thank you,

Chad Fisher

HVAC Equipment Sales



Powers of Arkansas

1219 Wagon Wheel Rd, Springdale, AR 72764



From: Shawn Shoemaker <sshoemaker@powersar.com>
Sent: Wednesday, April 1, 2020 5:14 PM
To: Chad Fisher <cfisher@powersar.com>; Christopher Lomax <clomax@powersar.com>; David Squires <DSquires@powersar.com>
Subject: Sapulpa job

Gentleman I need an answer for this by noon Tomorrow please on the AAON equipment for Sapulpa

Shawn Shoemaker
Tulsa Mechanical Service Manager
Powers
918-340-4768
sshoemaker@powersar.com
www.powersar.com

Begin forwarded message:

From: Pete Sellers <psellers@sapulpapolice.com>
Date: April 1, 2020 at 3:42:25 PM CDT
To: Shawn Shoemaker <sshoemaker@powersar.com>, Shell Kincheloe <sk@acserviceok.com>

Gentlemen,
We also need to know anticipated delivery of the units, is the COVID-19 going to delay the delivery?

Pete Sellers
Deputy Chief
Sapulpa Police Department
918 227-5102
psellers@sapulpapolice.com

256,530.11

BIDDER INFORMATION SHEET

To be completed by all Bidders
For Contracts/BID PROPOSALS with
the City of Sapulpa
(Please print in ink or type)

Project/Bid No. or Description COS10079 REPLACEMENT OF ROOF TOP HVAC UNITS
(SAPULPA POLICE DEPARTMENT)

Full Name of Bidder Mechanical Service Company DBA Powers-MSC

Legal Identity Corporation
(Corporation, Partnership,
Individual, etc.)

Address 5440 Northshore Drive
North Little Rock, AR 72118

Telephone No. 501-374-5420

Fax No. 501-370-9298

Taxpayer Identification No. 20-0651556

Contact Person Shawn Shoemaker

E-mail address (Optional) sshoeemaker@powersar.com

BID FORM

I, Mechanical Service Company DBA Powers-MSC (Bidder), having read all the specifications and requirements in the bid documents, do hereby propose to furnish: **materials and supplies at a firm price of:**

\$ 256,530.11

Number of days (after award) for delivery:
70 days

Company Mechanical Service Company DBA Powers-MSC

Name Shawn Shoemaker

Title Service Manager Oklahoma Mechanical

Signature *SLB* Date 3/25/20

I attest that the above signature is true and valid.

Teresa Belote
Notary

My commission expires: 8/9/2029

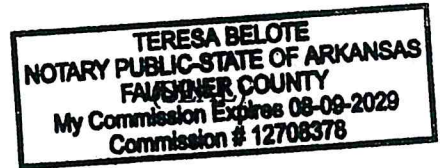

(This form must be notarized or bid will be rejected.)

**CITY OF SAPULPA
AFFIDAVITS**

STATE OF Oklahoma }
 } SS
COUNTY OF Creek }

1. Shawn Shoemaker, of lawful age, being first duly sworn, on oath, says that (s) he is the agent authorized by the bidder to submit the attached bid. Affiant further states that the nature of any partnership, joint venture, or other business relationship presently in effect or which existed within one (1) year prior to the date of this statement with the architect, engineer, or other party to the project is as follows:

Affiant further states that the names of all persons having any such business relationships and positions they hold with their respective companies or firms are as follows:

(If none of the business relationships herein above mentioned exist, affiant should so state.)

2. Affiant states that no officer or employee of the City of Sapulpa either directly or indirectly, owns any interest in the bidder's business.

Affiant further states that the following officer's and/or employee of the City of Sapulpa have some direct or indirect interest in the bidder's business.

3. Affiant further states that the bidder has not been a part to any collusion among bidders in restraint of freedom of competition by agreement to bid at a fixed price or to refrain from bidding; or with any State, County, or City official or employee as to quantity, quality, or price in the prospective Contract, or in any other terms of said prospective Contract; or in any discussions between bidder and any State, County, or City official concerning exchange of money or other thing of value for special consideration in the letting of a Contract.

Further Affiant Sayeth Not.

[Handwritten Signature]
Signature

Service Manager Oklahoma Mechanical
Title

Subscribed and sworn to before me this 24th day of March,
_____.

[Handwritten Signature]
Notary Public

My Commission Expires: 8/9/2029

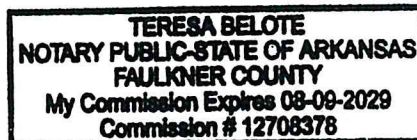

CITY OF SAPULPA

AGREEMENT

THIS AGREEMENT, made this 25th, day of, March, 2020, between the City of Sapulpa, hereinafter called OWNER and, Mechanical Service Company DBA Powers-MSG doing business as a Corporation, (Individual, partnership, or corporation) hereinafter called the CONTRACTOR.

WITNESSETH: That for and in consideration of the payments and agreements hereinafter mentioned:

1. The Contractor will commence and complete Project, as shown in the plans and specifications.
2. The Contractor will furnish all of the material, supplies and labor and other services necessary for the completion of the Project described in specifications.
3. The Contractor will commence the work required in the specifications within ten (10) calendar days after the date of the **Notice To Proceed** and will complete the same within sixty (60) calendar days unless the period for completion is extended by agreement of both parties.
4. The Contractor agrees to perform all of the Work described in the Specifications and comply with the terms therein for the sum not to exceed \$33,400 for BTW Recreation Center and \$31,400 for the Library.
5. During the Continuance of this Contract, the Contractor shall carry public liability insurance, property damage insurance up to the limits of the Tort Claims Act and Workman's Compensation Insurance as required by the State of Oklahoma.

Property:	\$ 25,000
Personal Injury, each person:	\$ 100,000
Personal Injury Aggregate:	\$1,000,000
Property, Aggregate	\$ 100,000
6. Contractor shall hold the City harmless for any loss, damage or claims arising from or related to your performance of the Agreement herein. Contractor must exercise all reasonable and customary precaution to prevent any harm or loss to all persons and property related to this Agreement.

7. The Contractor shall furnish certificates of insurance which shall provide that such insurance will not be canceled by the insurer without the insurer first giving the Owner ten (10) days written notice of cancellation.
8. Before executing this Agreement, the Contractor shall furnish the Owner for approval a list of sub-contractors proposed by the Contractor for us in this project, if applicable. Included in the listing shall be a detailed accounting of the work to be performed by respective sub-contractors. The Contractor under contract shall be solely responsible for maintaining the progress of work done by the sub-contractors. Failure of the subcontractor to complete such work in a timely manner does not relieve the Contractor from contractual obligations with Owner and/or any penalties imposed on the Contractor by the Owner.
Definition of Sub-Contractor: An individual, partnership, joint venture, firm or corporation, being a separate and independent entity, to whom the Contractor contracts part of the work under contract. Insurance requirements: In the event that any of the work to be performed by the Contractor on the project is sublet or assigned or is otherwise to be performed by any one other than the Contractor's own employees, then the insurance specified for the Contractor shall be extended to cover such work.

9. TIME AND PROGRESS

- A. The work shall be commenced within ten (10) days from and after the date of a written order from the Owner. The Contractor agrees that the work shall be prosecuted regularly, diligently, and uninterruptedly at a uniform rate of progress so as to insure completion within the number of days stated in Section three (3) of this Agreement. It is expressly understood and agreed that the said time for the completion of the work described herein is a reasonable time for the completion of the same.
- B. The Contractors may be required to furnish the owner with a progress schedule in a format approved by the Owner, setting forth in detail the procedure he proposes to follow, and giving the date on which he expects to start and to complete separate portions of the work. If at any time, in the opinion of the Owner, proper progress is not being maintained, such changes shall be made in the schedule of operations which will satisfy the Owner that the work will be completed within the period stated in the proposal.
- C. If the Contractor shall fail to complete the work within the specified time, then the contractor agrees to pay to the Owner, not as a penalty, but as liquidated damages for such breach of Contract, the sum of \$100.00 for each day of failure to complete the work after the specified impracticability and extreme

difficulty of fixing and ascertaining the actual damage the Owner would in such event sustain.

- D. It is further agreed that time is of the essence of each and every portion of this Contract and the specifications wherein a definite and certain time is fixed for the performance of any act whatsoever; and where under the contract an allowance of extra time for the completion of any work is made, the new time fixed by such extension shall be of the essence of this Contract.
 - E. Should the Contractor be delayed in the final completion of the work by any act or neglect of the Owner, or of any employees of either, or by strikes, injunctions, fire, or other cause or causes outside of and beyond the control of the Contractor and which, in the opinion of the Owner, could have been neither anticipated nor avoided, then an extension of time sufficient to compensate for the delay, as determined by the Owner, shall be granted by the Owner, provided, however, that the Contractor shall give the Owner notice in writing of the cause of the delay in each case within ten (10) days after the delay.
 - F. Extensions of time will not be granted based on inadequate construction force, or the failure of the Contractor to place orders for equipment or materials a sufficient time in advance to insure delivery when needed. Extensions of time will be provided if, in the opinion of the Owner, weather conditions have prevented performance within the time as herein specified. Any extension of time by the Owner shall not release the Contractor and surety herein from payment of liquidated damages for a period of time not included in the original Contract or the time extension as herein provided.
 - G. Failure to complete the project within the specified time, as set forth in this Contract may be grounds for disqualification for future contracts with the City of Sapulpa.
10. **BONDS:** In the event the Bid amount is over \$25,000.00, the Contractor shall provide the City of Sapulpa with a Bid Bond or certified check as part of the sealed bid, such bond or check shall be 5% of the bid. In addition, Statutory, Performance and Maintenance Bonds shall be furnished to the City of Sapulpa, in the amount awarded, prior to execution of the Agreement.

(Name of Bid Con't)

OWNER

By _____

Name _____
(Please Type)

Title _____

APPROVED AS TO FORM

By _____

Name _____

Title _____

ATTEST: (SEAL)

APPROVED AS TO FORM:

Shirley Burzio, City Clerk

David Widdoes, City Attorney

TERESA BELOTE
NOTARY PUBLIC-STATE OF ARKANSAS
FAULKNER COUNTY
My Commission Expires 08-09-2029
Commission # 12708378

CONTRACTOR:

Name Mechanical Service Company DBA Powers-MSC

By Shawn Shoemaker

Title Service Manager Oklahoma Mechanical

ATTEST: (SEAL)

Teresa Belote
Name - Please Type

My Commission Expires:

8/9/2029



BID BOND

KNOW ALL MEN BY THESE PRESENTS,

That we, Mechanical Service Company DBA Powers- MSC
as Principal, hereinafter called the Principal, and Arch Insurance Company
_____ a corporation duly organized under the laws of the State

Of Missouri
as Surety, hereinafter called the Surety, are held and firmly bound unto City of Sapulpa, Oklahoma

as Obligee, hereinafter called the Obligee, in the sum of Five Percent of Amount Bid
_____ Dollars (5% of Bid _____),

for the payment of which sum well and truly to be made, the said Principal and the said Surety, bind ourselves, our heirs, executors, administrators, successors and assigns, jointly and severally, firmly by these presents.

WHEREAS, the Principal has submitted a bid for
Bid No. COS10079 Replacement of Roof Top HVAC Units (Sapulpa Police Department)

NOW, THEREFORE, if the Obligee shall accept the bid of the Principal and the Principal shall enter into a Contract with the Obligee in accordance with the terms of such bid, and give such bond or bonds as may be specified in the bidding or Contract Documents with good and sufficient surety for the faithful performance of such Contract and for the prompt payment of labor and material furnished in the prosecution thereof, or in the event of the failure of the Principal to enter such Contract and give such bond or bonds, if the Principal shall pay to the Obligee the difference not to exceed the penalty hereof between the amount specified in said bid and such larger amount for which the Obligee may in good faith contract with another party to perform the Work covered by said bid, then this obligation shall be null and void, otherwise to remain in full force and effect.

Signed and sealed this 25th day of March, 2020

Elizabeth Browning
(Witness)

Mechanical Service Company DBA Powers- MSC
(Principal) (Seal)

Kouyfoye, Sec
(Title)

Kouyfoye
(Seal) (Witness)

Arch Insurance Company
(Surety)

Elizabeth Browning
Elizabeth Browning, Attorney-in-Fact (Title)

THIS POWER OF ATTORNEY IS NOT VALID UNLESS IT IS PRINTED ON BLUE BACKGROUND.

This Power of Attorney limits the acts of those named herein, and they have no authority to bind the Company except in the manner and to the extent herein stated. Not valid for Note, Loan, Letter of Credit, Currency Rate, Interest Rate or Residential Value Guarantees.

POWER OF ATTORNEY

Know All Persons By These Presents:

That the Arch Insurance Company, a corporation organized and existing under the laws of the State of Missouri, having its principal administrative office in Jersey City, New Jersey (hereinafter referred to as the "Company") does hereby appoint:

Elizabeth M. Browning, Felecia Prince, John M. Harbour, Jr., Stanley G. Payne, Stephanie R. Jones and William G. Cobb, Jr. of Little Rock, AR (EACH)

its true and lawful Attorney(s)in-Fact, to make, execute, seal, and deliver from the date of issuance of this power for and on its behalf as surety, and as its act and deed:

Any and all bonds, undertakings, recognizances and other surety obligations, in the penal sum not exceeding Ninety Million Dollars (\$90,000,000.00).

This authority does not permit the same obligation to be split into two or more bonds In order to bring each such bond within the dollar limit of authority as set forth herein.

The execution of such bonds, undertakings, recognizances and other surety obligations in pursuance of these presents shall be as binding upon the said Company as fully and amply to all intents and purposes, as if the same had been duly executed and acknowledged by its regularly elected officers at its principal administrative office in Jersey City, New Jersey.

This Power of Attorney is executed by authority of resolutions adopted by unanimous consent of the Board of Directors of the Company on September 15, 2011, true and accurate copies of which are hereinafter set forth and are hereby certified to by the undersigned Secretary as being in full force and effect:

"VOTED, That the Chairman of the Board, the President, or the Executive Vice President, or any Senior Vice President, of the Surety Business Division, or their appointees designated in writing and filed with the Secretary, or the Secretary shall have the power and authority to appoint agents and attorneys-in-fact, and to authorize them subject to the limitations set forth in their respective powers of attorney, to execute on behalf of the Company, and attach the seal of the Company thereto, bonds, undertakings, recognizances and other surety obligations obligatory in the nature thereof, and any such officers of the Company may appoint agents for acceptance of process."

This Power of Attorney is signed, sealed and certified by facsimile under and by authority of the following resolution adopted by the unanimous consent of the Board of Directors of the Company on September 15, 2011:

VOTED, That the signature of the Chairman of the Board, the President, or the Executive Vice President, or any Senior Vice President, of the Surety Business Division, or their appointees designated in writing and filed with the Secretary, and the signature of the Secretary, the seal of the Company, and certifications by the Secretary, may be affixed by facsimile on any power of attorney or bond executed pursuant to the resolution adopted by the Board of Directors on September 15, 2011, and any such power so executed, sealed and certified with respect to any bond or undertaking to which it is attached, shall continue to be valid and binding upon the Company.





COOK

SUBMITTAL

PROJECT: SAPULPA PD EXHAUST

SUBMITTED BY: Chase Ransom
Powers of Arkansas
1219 Wagon Wheel Rd
Springdale, AR 72764

PHONE: 479-927-9999
FAX: 479-927-9848
E-MAIL: cransom@powersar.com

DATE: 4/2/2020

LOREN COOK COMPANY



Corporate Offices: 2015 E. Dale Street, Springfield, MO 65803 • P.O. Box 4047, Springfield, MO 65808
417.889.8474 • fax 417.889.2520
lorencook.com



COOK



MARK: GARAGE EF
PROJECT: SAPULPA PD EXHAUST
DATE: 4/2/2020

ACE-B

**Downblast Centrifugal
Exhaust Ventilator
Roof Mounted/Belt Drive**

STANDARD CONSTRUCTION FEATURES:

All aluminum housing - Backward inclined all aluminum wheel - Two piece top cap with stainless steel quick release latches - Welded curb cap corners - Birdscreen - Vibration isolators - Lifting Lugs - Permanently lubricated ball bearing motors - Oil and heat resistant, static conducting belts - Adjustable pitch drives through 5 hp motor - Corrosion resistant fasteners - Regreasable bearings in a cast iron pillow block housing, rated at 200,000 hours average life - All fans factory adjusted to specified fan RPM - Transit tested packaging - Standard motors ship factory installed.

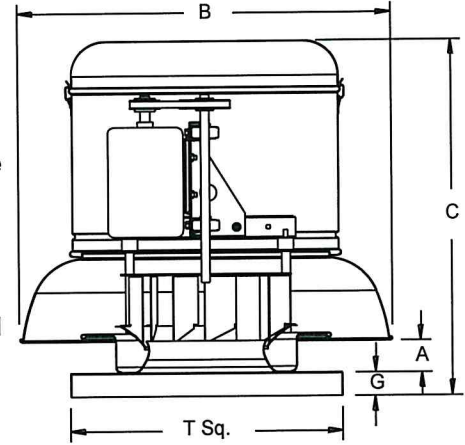

Performance (*Bhp includes 7% drive loss)

Qty	Catalog Number	Flow (CFM)	SP (inwc)	Fan RPM	Power* (HP)	FEG
1	300C9B	9000	.350	587	1.72	60

Altitude (ft): 715 Temperature (F): 70

Motor Information

HP	RPM	Volts/Ph/Hz	Enclosure	FLA	Mounted
2	1725	115/1/60	ODP -SE	24	Yes

FLA based on NEC (2014) Table 430.248

Sound Data Inlet Sound Power by Octave Band

1	2	3	4	5	6	7	8	LwA	dBA	Sones
83	84	81	73	71	67	58	52	77	66	14.7

Accessories:

- DRIVES (1.5 SF) @ 587 RPM
- DISCONNECT NEMA 3 PRE-WIRED L-T
- BD-30 DAMPER
- ROOF CURB RCG 34-13.5H W/TRAY
- EXTENDED LUBE LINES
- BELT TENSIONR-ROTARY
- SPARE BELT SET

Dimensions (inches)

A	7-1/16
B	52-5/8
C	49-1/16
G	3
T Sq.	36
Roof Open.Sq.*	31-1/2

NOTE: Accessories may affect dimensions shown.

Weight(lbs)***	Shipping	467	Unit	303
----------------	----------	-----	------	-----

*Roof opening size for curbs supplied by Cook only.
***Includes fan, motor & accessories.

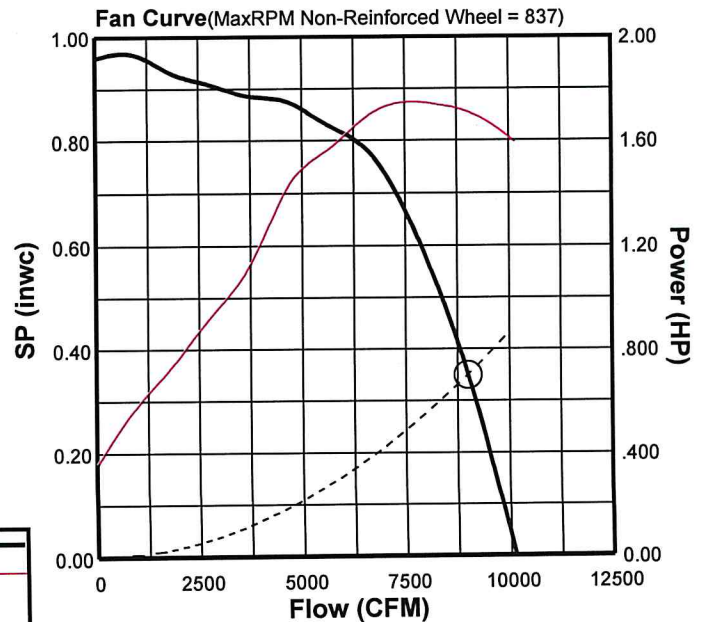



COOK

PROJECT: SAPULPA PD EXHAUST
DATE: 4/2/2020

BD

Gravity Backdraft Damper

STANDARD CONSTRUCTION FEATURES:

.02 Aluminum blades - .06 aluminum frame -
Aluminum hinge pins - Nylon bushings.

Note:

Sizes 36 thru 60 are shipped as 2 panels.
Sizes 66 and 78 are shipped as 6 panels.
These may require assembly.

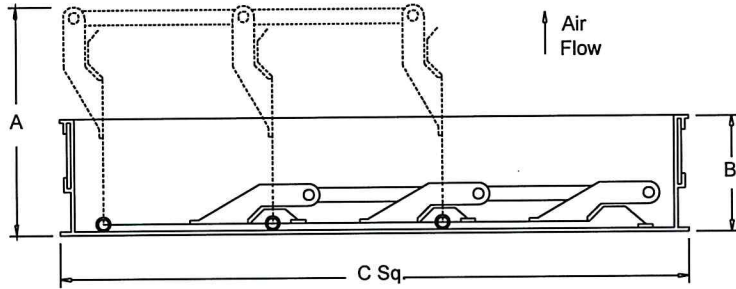

Dimensions (inches)

Mark	Qty	Description	A Max.	B	C Sq.	# Panels
GARAGE EF	1	BD-30 DAMPER	5-3/16	1-7/8	29-3/4	1



COOK

PROJECT: SAPULPA PD EXHAUST

DATE: 4/2/2020

RCG

Galvanized Steel Roof Curb

STANDARD CONSTRUCTION FEATURES:

18 gauge galvanized steel - 1-1/2",
 3 lbs. density thermal and acoustical
 insulation - Continuously welded corners -
 Wood nailer.

Options:(As noted below*)

- 1) No wood nailer (deduct 1-1/2" for actual height).
- 2) Damper tray.

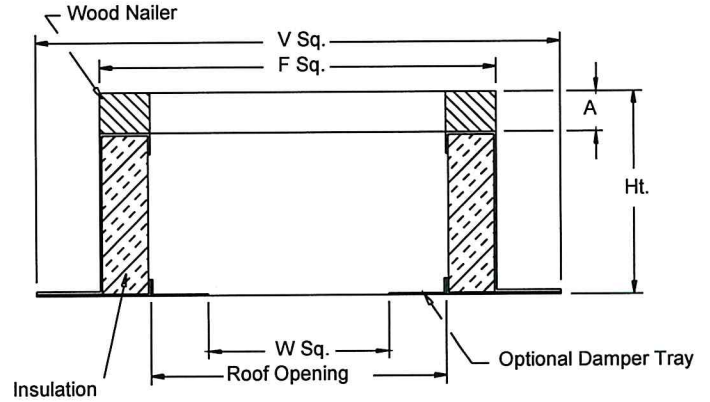

Dimensions (inches)

Mark	Qty	Description	Ht	Options*	A	F Sq.	V Sq.	W Sq.	Roof Opening
GARAGE EF	1	RCG 34	13.5	2;	1-1/2	34-1/2	38-1/2	27-3/4	31-1/2



COOK



MARK: PROPERTY EF

PROJECT: SAPULPA PD EXHAUST

DATE: 4/2/2020

ACE-D

**Downblast Centrifugal
Exhaust Ventilator
Roof Mounted/Direct Drive**

STANDARD CONSTRUCTION FEATURES:

All aluminum housing - Backward inclined all aluminum wheel - Two piece top cap with stainless steel quick release latches (sizes 120 - 300) - Welded curb cap corners - Birdscreen - Permanently lubricated ball bearing motors - Corrosion resistant fasteners - Transit tested packaging.

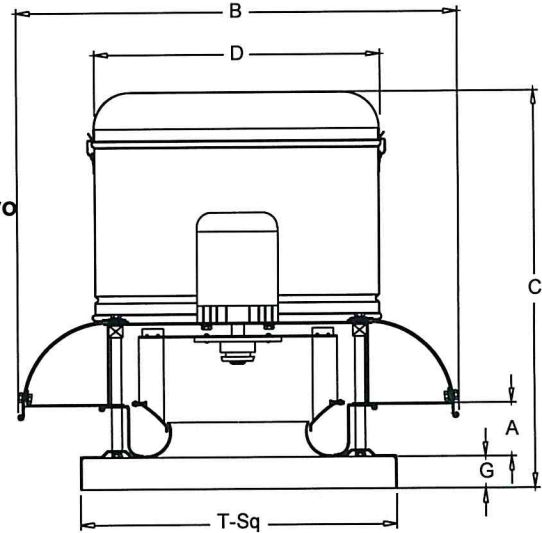

Performance

Qty	Catalog Number	Flow (CFM)	SP (inwc)	Fan RPM	Power (HP)	FEG	Speed Control
1	150C15D	2000	.350	1115	.287	n/a(<1HP)	FSC

Altitude (ft): 715 Temperature (F): 70

Motor Information

HP	RPM	Volts/Ph/Hz	Enclosure	TOL
3/4	1550	115/1/60	ODP -SE	Yes

Sound Data Inlet Sound Power by Octave Band

1	2	3	4	5	6	7	8	LwA	dBA	Sones
73	76	77	69	66	62	56	51	73	61	11.1

Accessories:

- DISCONNECT NEMA 3 PRE-WIRED L-T
- BD-18 DAMPER
- ROOF CURB RCG 22-13.5H W/TRAY
- FAN SPEED CONTROLLER 10A 120V PREWIRE

Dimensions (inches)

A	2-13/16
B O.D.	32-7/8
C	29-3/16
D O.D.	23-13/16
G	2
T Sq.	24
Roof Open. Sq.*	19-1/2

NOTE: Accessories may affect dimensions shown.

Weight(lbs)***	Shipping	94	Unit	68
----------------	----------	----	------	----

* Roof opening size for curbs supplied by Cook only.
***Includes fan, motor & accessories.

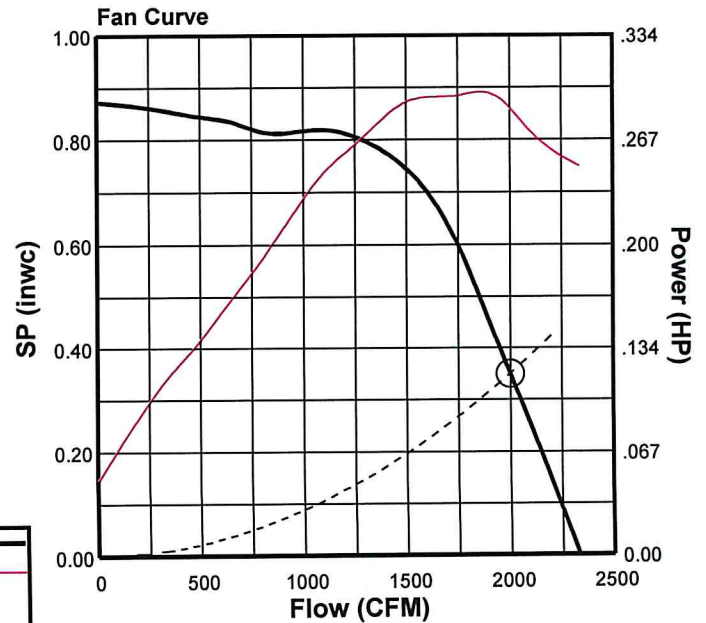



COOK

PROJECT: SAPULPA PD EXHAUST

DATE: 4/2/2020

BD

Gravity Backdraft Damper

STANDARD CONSTRUCTION FEATURES:

.02 Aluminum blades - .06 aluminum frame -
Aluminum hinge pins - Nylon bushings.

Note:

Sizes 36 thru 60 are shipped as 2 panels.
Sizes 66 and 78 are shipped as 6 panels.
These may require assembly.

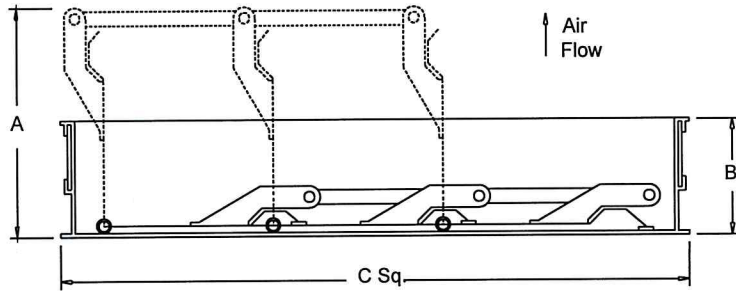

Dimensions (inches)

Mark	Qty	Description	A Max.	B	C Sq.	# Panels
PROPERTY EF	1	BD-18 DAMPER	5-3/16	1-7/8	17-3/4	1



COOK

PROJECT: SAPULPA PD EXHAUST

DATE: 4/2/2020

RCG

Galvanized Steel Roof Curb

STANDARD CONSTRUCTION FEATURES:

18 gauge galvanized steel - 1-1/2",
 3 lbs. density thermal and acoustical
 insulation - Continuously welded corners -
 Wood nailer.

Options:(As noted below*)

- 1) No wood nailer (deduct 1-1/2" for actual height).
- 2) Damper tray.

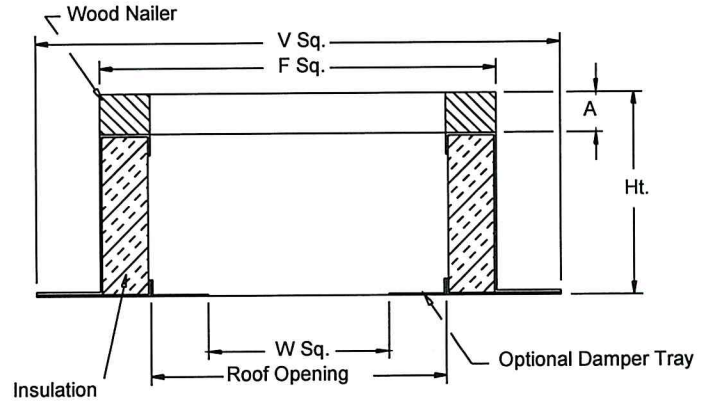

Dimensions (inches)

Mark	Qty	Description	Ht	Options*	A	F Sq.	V Sq.	W Sq.	Roof Opening
PROPERTY EF	1	RCG 22	13.5	2;	1-1/2	22-1/2	26-1/2	15-3/4	19-1/2



COOK

PROJECT: SAPULPA PD EXHAUST
DATE: 4/2/2020

FSC

Fan Speed Controls

STANDARD CONSTRUCTION FEATURES:

PRODUCT DESCRIPTION - Through the "Quadrac" integrated semi-conductor device it is now possible to offer this system with many advantages. Fewer semi-conductor parts mean greater reliability and the passivation process used in the manufacture of the semi-conductor insures long life.

Printed circuit construction eliminates wiring difficulties and guarantees workmanship.

All of these factors serve to offer the most important of all features - quality.

SPEED CONTROL - Positive Off/On action in the control dial. Speed range set to the customer's requirements.

CONTROL RATING - 120 volts, 60 cycles, 1 phase. Maximum ambient temperature - 120 degree F (5 AMP, 10 AMP, 15 AMP). 220/240 volt, 50/60 cycles, 1 phase. Maximum ambient

temperature - 120 degree F (5 AMP, 10 AMP). 220/240 volt model not UL listed. Fan cannot have

UL listing if furnished with prewired 220/240 volt FSC. 277 volt, 60 cycles, 1 phase.

Maximum ambient temperature - 120 degree F (5 AMP). **WARNING** - Power must be turned off

before installing this unit. **STANDARD INSTALLATION** - Fits any standard single gang box.

Turn off power and connect the two wires on the control to the two switch wires in the

usual manner. The connection box is not supplied. **SPECIAL FEATURES** - Complete range control,

solid state "Quadrac" integrated circuitry, solid state construction for long reliable

operating life, saves on electric bills.

Dimensions (inches)

Mark	Qty	Description
PROPERTY EF	1	FSC 10A 120V PREWIRE

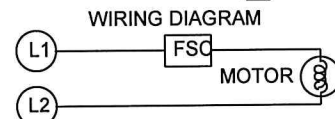
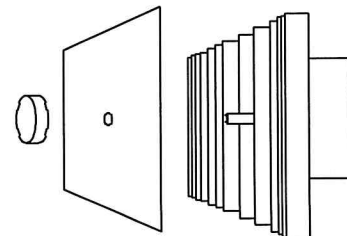
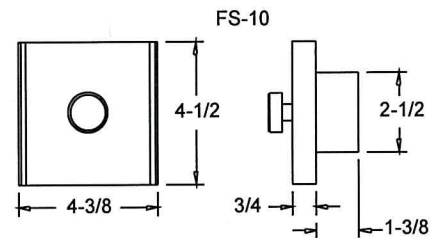
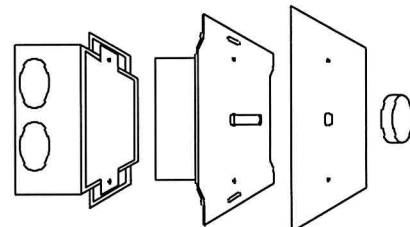
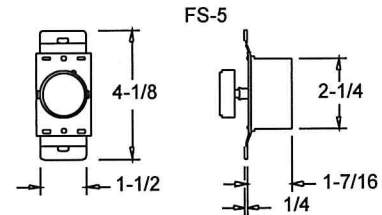



COOK

PR

Spun Aluminum Intake/Relief Ventilator

STANDARD CONSTRUCTION FEATURES:
All aluminum construction - Anti-backdraft flange - Five year warranty.

Performance

Qty	Catalog Number	Flow (CFM)	SP (inwc)
1	36 PR	12289	.341

Altitude (ft): 715 Temperature (F): 70

Accessories:

BDI-42 DAMPER
ROOF CURB RCG 46-13.5H W/TRAY
BIRDSCREEN

MARK: GARAGE INTAKE HOOD
PROJECT: SAPULPA PD EXHAUST
DATE: 4/2/2020

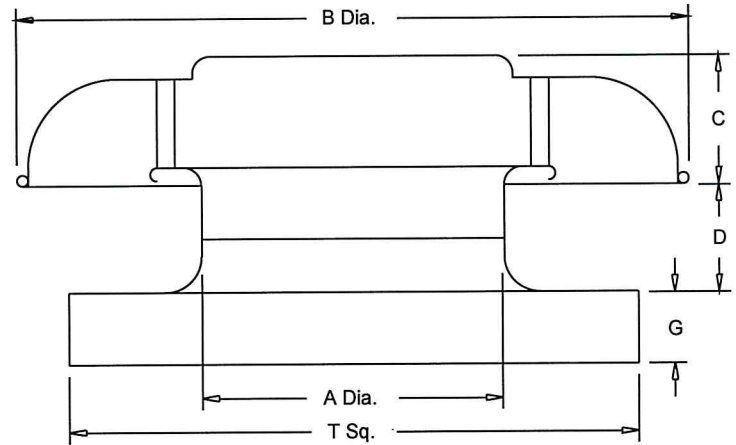

Dimensions (inches)

A Dia.	36-3/4
B Dia.	62-5/8
C	17-1/2
D	7-1/2
G	3
T Sq.	48
Roof Open.	43-1/2

NOTE: Accessories may affect dimensions shown.

Weight(lbs)***	Shipping	391	Unit	212
----------------	----------	-----	------	-----

***Includes accessories.



COOK

PROJECT: SAPULPA PD EXHAUST

DATE: 4/2/2020

BDI

Intake Backdraft Damper

STANDARD CONSTRUCTION FEATURES:

.02 Aluminum blades - .06 aluminum frame -
.08 aluminum wrapper - Spring return to
close - Aluminum hinge pins - Nylon
bushings.

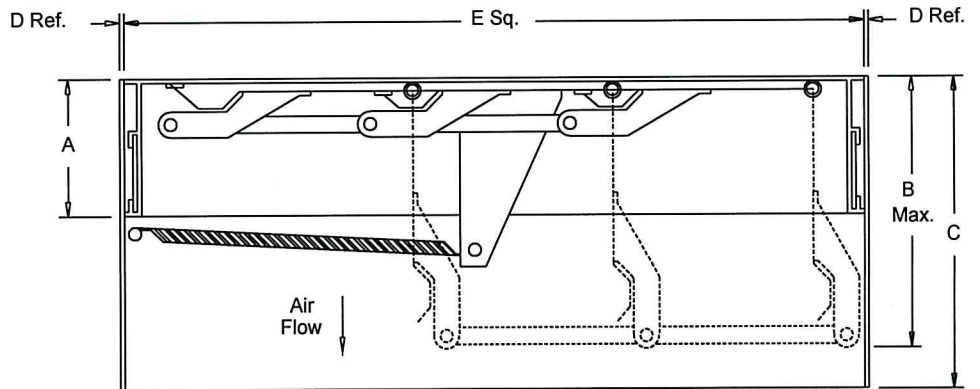

Dimensions (inches)

Mark	Qty	Description	A	B Max.	C	D	E Sq.
GARAGE INTAKE HOOD	1	BDI-42 DAMPER	1-7/8	5-3/16	6	1/8	41-3/4



COOK

PROJECT: SAPULPA PD EXHAUST
DATE: 4/2/2020

RCG

Galvanized Steel Roof Curb

STANDARD CONSTRUCTION FEATURES:

18 gauge galvanized steel - 1-1/2",
 3 lbs. density thermal and acoustical insulation - Continuously welded corners - Wood nailer.

Options:(As noted below*)

- 1) No wood nailer (deduct 1-1/2" for actual height).
- 2) Damper tray.

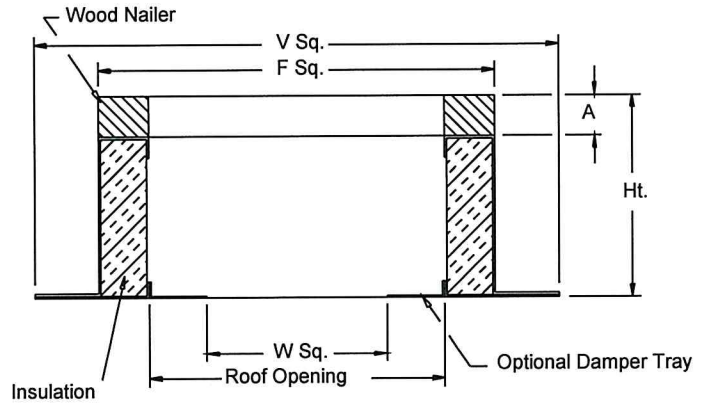

Dimensions (inches)

Mark	Qty	Description	Ht	Options*	A	F Sq.	V Sq.	W Sq.	Roof Opening
GARAGE INTAKE HOOD	1	RCG 46	13.5	2;	1-1/2	46-1/2	50-1/2	39-3/4	43-1/2

Blower Standard Construction Features

- * Heavy duty relubricatable, self-aligning bearings rated for 200,000 hours average life.
- * Precision turned ground & polished solid steel shafts sized for critical speed of 125% max cataloged conditions.
- * All steel components Lorenized with an electrostatically applied baked polyester powder coating.
- * Integral adjustable motor mounting plate on arrangements 9 and 10.
- * Dynamically balanced wheels.
- * Static resistant belts.
- * Pre-punched mounting holes.
- * Lifting lugs on all sizes.
- * Corrosion resistant fasteners.

PRODUCT SPECIFIC FEATURES:

CIC - Inline Centrifugal Blower

UL 705 Listed * AMCA Air and Sound certified performance * Flanged outlet * Inlet collar for slip-fit duct connection * Fully welded straightening vanes * Lube lines extended to exterior of unit * Continuously welded, high efficiency airfoil wheel * Heavy gauge spun aluminum inlet cone * Continuously welded heavy gauge housing.

CA – Airfoil Centrifugal Blower

UL 705 Listed * AMCA Air and Sound certified performance * Flanged outlet * Inlet collar for slip-fit duct connection on arrangements 1, 2, 9 and 10 * Continuously welded, high efficiency airfoil wheel * Heavy gauge spun aluminum inlet cone * Continuously welded heavy gauge housing.

CF – Backward Inlet Centrifugal Blower

UL 705 Listed * AMCA Air certified performance * Flanged outlet * Inlet collar for slip-fit duct connection on arrangements 1, 2, 9 and 10 * Continuously welded, heavy duty flat blade wheel * Heavy gauge spun aluminum inlet cone * Continuously welded heavy gauge housing.

CPS/CPA – Arr. 10 Vent Set

UL 705 Listed * AMCA Air certified performance * Field rotatable housings * AMCA 'A' all aluminum airstream construction on CPA * Flanged outlet * Inlet collar for slip-fit duct connection * Continuously welded, heavy duty flat blade wheel * Heavy gauge spun aluminum inlet cone * Continuously welded housing.

CPS-A/CPA-A – Arr. 10 Vent Set

Field rotatable housings * AMCA 'A' all aluminum airstream construction on CPA-A * Flanged outlet * Inlet collar for slip-fit duct connection * Continuously welded, high efficiency airfoil wheel * Heavy gauge spun aluminum inlet cone * Continuously welded housing.

CPV – Arr. 10 Vent Set

UL 705 Listed * AMCA Air and Sound certified performance * Field rotatable housings * Flanged outlet * Inlet collar for slip-fit duct connection * All aluminum flat blade wheel * Heavy gauge spun aluminum inlet cone * Continuously welded housing.

CPFB/CPFD – Vent Set

UL 705 Listed * AMCA Air and Sound certified performance * Field rotatable housings * Flanged outlet on CPFB, slip-fit outlet on CPFD * Inlet Collar for slip-fit inlet duct connection * Forward curved wheel * Heavy gauge spun aluminum inlet cone in CPFB, steel inlet on CPFD * Continuously welded housing on CPFB.

GCP – Plug Fan

UL 705 Listed * AMCA Air and Sound certified performance * Heavy gauge mounting panel with welded corners * Continuously welded, airfoil and flat blade wheel available * Heavy gauge spun aluminum inlet cone.

PLC – Plenum Fan

UL 705 Listed * AMCA Air and Sound certified performance * Heavy duty structural steel frame with heavy gauge inlet panel welded at all connections * Continuously welded airfoil wheel * Heavy gauge spun aluminum inlet cone.

CFS – Centrifugal Filtered Supply Fan

UL 705 Listed * Continuously welded, high efficiency airfoil wheel * Extruded aluminum tiers with continuously welded and mitered corners * Removable aluminum top cap with welded corners * Permanent removable washable filters * Continuously welded heavy gauge blower housing.

IMH – Industrial Material Handler

AMCA Air certified performance * Field rotatable housing * Inlet collar for slip-fit duct connection * Continuously welded, heavy duty radial tip wheel * Continuously welded housing * Heavy duty structural steel housing supports.

- MH - Radial blades in an open wheel
- MHR - Rim reinforced, radial blades in an open wheel
- MHB - Radial, buttressed blades in a backplate wheel
- MHA - Backward inclined blades in a backplate wheel with a conical shroud

Job Name _____
 Purchaser _____
 Submitted to _____
 Unit Designation _____

Location _____
 Engineer _____
 Reference Approval Construction
 Schedule # _____

System Specifications

Performance	US Ton (nominal)		3.0
	Capacity (Btu/h)	Nominal Cooling ¹	38,000
		Nominal Heating ¹	42,000
	System Modulation down to (Btu/h)		7,500
	SEER	Ducted / Non-Ducted	16.0 / 14.8
	EER	Ducted / Non-Ducted	11.2 / 11.2
	HSPF	Ducted / Non-Ducted	8.6 / 8.8
Power	Voltage (øV/Hz)		1 / 208-230 / 60
	Maximum Circuit Breaker (MCCB/ELB/ELCB)		40
	Minimum Circuit Ampacity (MCA)		23
Indoor Units	Total Capacity (%)		50 - 130% Of Outdoor Capacity
	Maximum Indoor Unit Quantity		6
Compressor	Type		Twin BLDC Rotary X1
	RLA	A	17.3
Refrigerant	Type		R410A
	Factory Charge	lbs.	7.05
Pipe Connections	Liquid X Suction		3/8 X 5/8
Installation Limitation ²	Max. Distance - ODU to IDU (feet)		492 (574 equivalent)
	Vertical Separation (feet)	ODU to IDU	164 / 131
		Highest/Lowest IDU	49
	Total Refrigerant Pipe (feet)		984
Condenser Fan	Fan	Type	Propeller X 2
		Output (CFM)	3,885
	Motor	Type	BLDC
Output (W) / FLA (A)		125 X 2 / 0.6	
Dimensions	W X H X D	Inches	37 X 47 5/8 X 13
	Weight	lbs.	220
Sound Level	dB (A)	Max.	50
Operating Temperature Range	Cooling ³	*F	0 - 118
	Heating	*F	-4 - 75
Accessories	Wind Baffles	Front	<input checked="" type="checkbox"/> WBF-1M2
		Back	<input checked="" type="checkbox"/> WBB-2M
	Wi-Fi Adapter		<input type="checkbox"/> MIM-H03UN
	Mode Selector Switch For HP Systems		<input type="checkbox"/> MCM-C200U
Safety Certifications			ETL (UL 1995)
Protection Devices	Intelligent logic to ensure proper operation within unit design limitations and operational parameters		
	High pressure sensor, low pressure sensor, over-voltage protection, compressor over-current protection, current transformer, fan motor voltage protection, fan motor thermal protection, high voltage fuses		

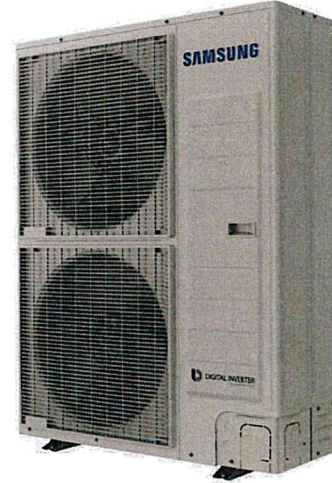

Compatibility

Only compatible with Samsung DVM S indoor units (AM****N**CH/AA)

Construction

The unit shall be galvanized steel with a baked on powder coated finish

Refrigerant pipe connections inside unit chassis with penetrations available on front, back, right, and bottom sides for versatile installation

Heat Exchanger

The heat exchanger shall be mechanically bonded fin to copper tube.

Salt spray test method: ASTM-B117-18 - the heat exchanger showed no unusual rust or corrosion development to 2,280 hours.

Controls

The unit shall be operated via NASA Protocol with controls provided by Samsung

Controls shall integrate with Samsung central controls without additional interface modules

The unit shall integrate with the Samsung NASA Controls Network Solution

Control wiring shall be 16 AWG X 2 shielded wire.

Refrigerant System

The compressors shall be Samsung hermetically sealed, inverter driven, twin BLDC Rotary type.

Refrigerant flow shall be controlled by EEV (electronic expansion valve) throughout the system.

A flat plate subcooler device will improve capacity at extreme system refrigerant pipe lengths and reduce refrigerant noise.

Other Features

Optional night quiet modes to reduce outdoor unit sound

Optional snow blowing logic to prevent snow drifting on idle outdoor units

¹ Certified in accordance with the AHRI Unitary Small Air-Source Heat Pumps (USHP) Certification Program which is based on the latest edition of AHRI Standard 210/240.

² Other pipe restrictions and requirements exist. Please consult installation manuals or technical data book for full details.

³ When cooling in outside temperatures between 0°F ~ 23°F, wind baffles are required. When outside temperature is between 0°F ~ 23°F, 50% operating capacity should be maintained to ensure reliability while in cooling mode.

Samsung HVAC maintains a policy of ongoing development, specifications are subject to change without notice.

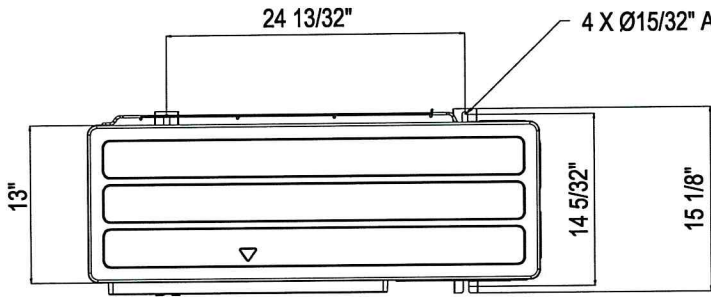

TO

37"

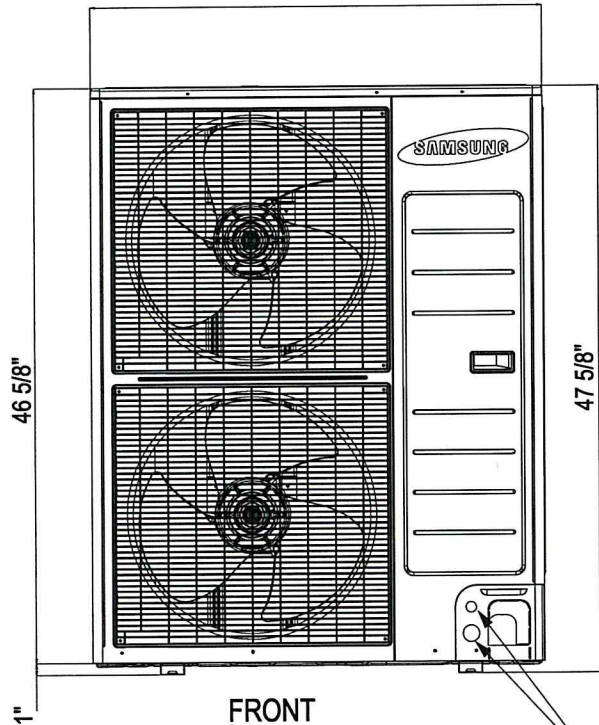

FRONT

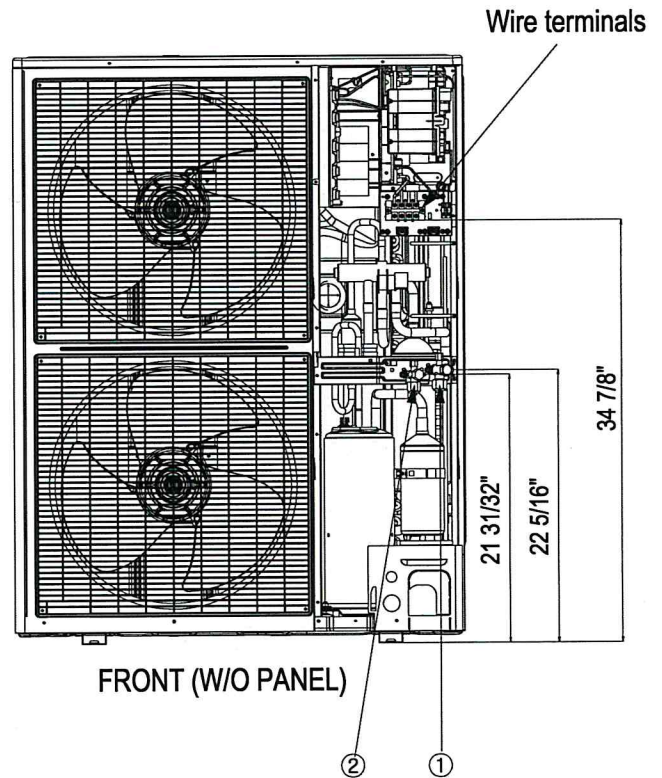

FRONT (W/O PANEL)

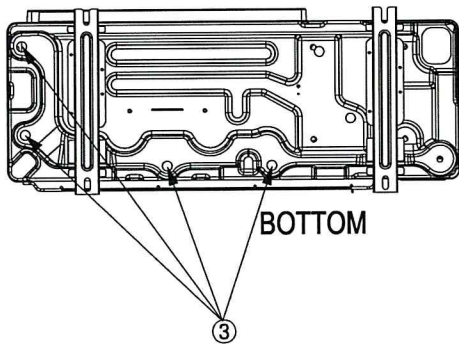

BOTTOM

- ① Gas refrigerant pipe opening
- ② Liquid refrigerant pipe opening
- ③ Condensate drain holes
- ④ Communication conduit opening (2 X Ø1 3/8")

Job Name _____
 Purchaser _____
 Submitted to _____
 Unit Designation _____

Location _____
 Engineer _____
 Reference Approval Construction
 Schedule # _____

Specifications

Performance	Nominal Capacity ¹	Cooling (Btu/h)	36,000
		Heating (Btu/h)	40,000
Power	Voltage (øV/Hz)		1 / 208 - 230 / 60
	Current Input	Cooling/Heating (A)	0.94 / 0.83
Fan	Type		Sirocco X 4
	Motor	Type	BLDC
		Output (W)	260 X 1
Airflow	CFM (UL)	L/M/H	653 / 844 / 1,035
Refrigerant	Type		R410A
	Control Method		Electronic Expansion Valve
Piping Connections	Liquid (flare)	Inches	3/8
	Suction (flare)	Inches	5/8
	Drain	Inches	VP25 (OD 1 1/4, ID 1)
Unit Dimensions	W X H X D	Inches	53 1/8 X 9 1/4 X 26 9/16
	Weight	lbs.	73.85
Sound Level	L/M/H	dB	37 / 41 / 45
Accessories	External Temperature Sensor		<input type="checkbox"/> MRW-TA
	External Contact Control		<input type="checkbox"/> MIM-B14
	Wireless Controller		<input type="checkbox"/> AR-EH03U
	Condensate Pump	Aspen Maxi Orange	<input checked="" type="checkbox"/> ASP-MAXO-UNIV
		Blue Diamond	<input type="checkbox"/> BD-BLUE230
CN83 Pigtail (for external float switch connection)		<input type="checkbox"/> DB39-01263A	
Safety Certifications			ETL (UL 1995)

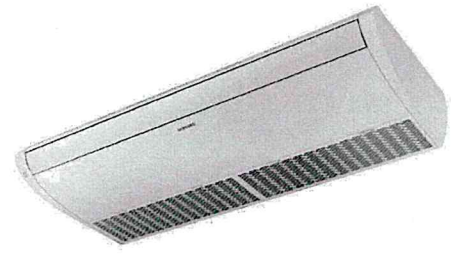

- Compatible with Samsung DVM S, DVM S Water, and DVM Eco systems (AM*****/AA).
- Washable electro-static filter as standard (included with unit)
- High-voltage terminal block temperature sensor to disable unit in the event overheating of power connection.
- Power and pipe connections are easily accessible from one side of the unit for simple installation and service.
- Powerful air throw for large areas
- Fresh air inlet to allow simple introduction of outside air.

Construction
 HIPS chassis certified to UL94 V0 with a galvanized steel base.

Heat Exchanger
 The heat exchanger shall be mechanically bonded fin to copper tube

Indoor Fan
 Indoor fan shall be sirocco type (4)

Three fan speed settings and auto setting

Controls
 The unit shall be operated via a wireless or wired remote control with DDC type signal

The unit shall integrate with the Samsung NASA Controls Network Solution

Controls shall integrate with a BMS system

Control wiring shall be 2 X 16 AWG shielded wire

¹ Nominal cooling capacities are based on: Indoor temperature: 80 °F DB, 67°F WB. Outdoor temperature: 95°F DB, 75°F WB.
 Nominal heating capacities are based on: Indoor temperature: 70 °F DB, 60°F WB. Outdoor temperature: 47°F DB, 43°F WB.
 Samsung HVAC maintains a policy of ongoing development, specifications are subject to change without notice.

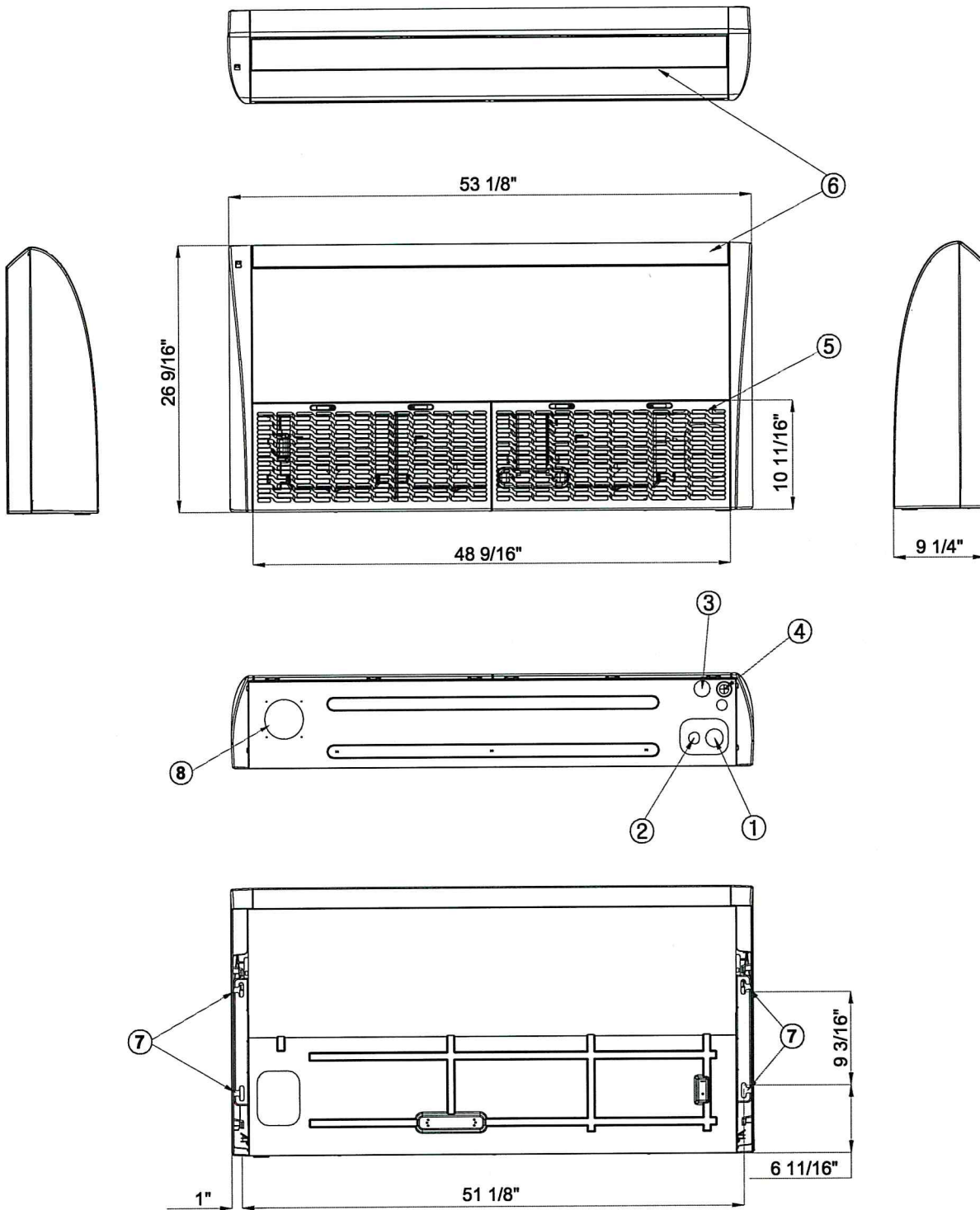

No.	Name	No.	Name
1	Gas Pipe Opening	5	Air Inlet
2	Liquid Pipe Opening	6	Discharge Air
3	Drain Pipe Opening	7	Suspension Hook
4	Conduit Opening	8	Fresh Air Inlet (4")



Unit Rating

2425 South Yukon Ave - Tulsa, Oklahoma 74107-2728 - Ph. (918) 583-2266 Fax (918) 583-6094
AAONEcat32 Ver. 4.292 (SN: 6303792-)

1A 1B 1C 1D 2 3 4 5A 5B 5C 6A 6B 6C 7 8 9 10 11 12 13 14A 14B 15 16 17 18 19 20 21 22 23

RN-010-8-0-KB09-2L2:A000-C00-DTD-B00-00EA00E-00-00C0000VB
Tag: RTU-1,7-VS

Job Information

Job Name: *SAPULPA POLICE DEPARTMENT*
Job Number: *SPD*
Site Altitude: *715 ft*
Refrigerant: *R-410A*

Unit Information

Approx. Op./Ship Weights: *1035 / 1035 lbs. (±5%)*
Supply CFM/ESP: *3000 / 0.6 in. wg.*
Final Filter FV / Qty: *337.50 fpm / 4*
Outside CFM: *900*
Ambient Temperature: *100 °F DB / 78 °F WB*
Return Temperature: *72 °F DB / 59 °F WB*

Static Pressure

External: *0.60 in. wg.*
Evaporator: *0.47 in. wg.*
Filters Clean: *0.13 in. wg.*
Dirt Allowance: *0.35 in. wg.*

Economizer: *0.08 in. wg.*
Heating: *0.09 in. wg.*
Cabinet: *0.12 in. wg.*
Total: *1.85 in. wg.*

Cooling Section

	Gross	Net
Total Capacity:	<i>114.21</i>	<i>109.29 MBH</i>
Sensible Capacity:	<i>86.98</i>	<i>82.06 MBH</i>
Latent Capacity:	<i>27.23 MBH</i>	
Mixed Air Temp:	<i>80.40 °F DB</i>	<i>65.57 °F WB</i>
Entering Air Temp:	<i>80.40 °F DB</i>	<i>65.57 °F WB</i>
Lv Air Temp (Coil):	<i>52.27 °F DB</i>	<i>52.12 °F WB</i>
Lv Air Temp (Unit)	<i>53.81 °F DB</i>	<i>52.76 °F WB</i>
Supply Air Fan:	<i>1 x RN170 @ 1.67 BHP</i>	
SA Fan RPM / Width:	<i>1806 / 3.810"</i>	
Evaporator Coil:	<i>8.5 ft² / 6 Rows / 14 FPI</i>	
Evaporator Face Velocity:	<i>352.7 fpm</i>	

Heating Section

PreHeat Type: *Std (No Preheat)*
Heating Type: *Nat. Gas Heat*
Heating CFM: *3000*
Total Capacity: *168.0 MBH*
OA Temp: *13.0 °F DB / 12.0 °F WB*
RA Temp: *72.0 °F DB / 59.0 °F WB*
Entering Air Temp: *54.3 °F DB / 48.2 °F WB*
Leaving Air Temp: *106.1 °F DB / 67.7 °F WB*
Input: *210.0 MBH*
Heater Qty: *1*
Consumption: *210.0 MBH*
Total Turndown Ratio: *1.4:1*

Rating Information

Cooling Capacity (MBH): *117.0*
Cooling EER: *11.1*
Cooling IEER: *21.5*
Rated in accordance with AHRI 340/360

Application EER @ Op. Conditions: *9.4*

Electrical Data

Rating: *208/3/60*
Unit FLA: *42*

Minimum Circuit Amp: *49*
Maximum Overcurrent: *70*

	Qty	HP	VAC	Phase	RPM	FLA	RLA
Compressor 1:	1		208	3			27.2
Condenser Fans:	1	1.00	208	1	1110	7.0	
Supply Fan:	1	2.00	208	3	1760	7.5	
Combustion:	1	0.09	208	1	3010	1.3	

Cabinet Sound Power Levels*

Octave Bands:	63	125	250	500	1000	2000	4000	8000
Discharge LW(dB):	82	80	84	80	72	69	67	61
Return LW(dB):	72	71	70	63	58	54	50	38

*Sound power levels are given for informational purposes only. The sound levels are not guaranteed.

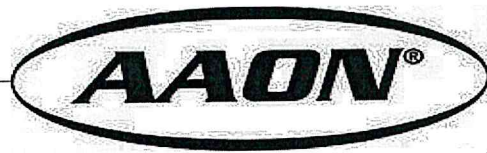

Unit Submittal

2425 South Yukon Ave - Tulsa, Oklahoma 74107-2728 - Ph. (918) 583-2266 Fax (918) 583-6094
AAONEcat32 Ver. 4.292 (SN: 6303792-)

1A 1B 1C 1D 2 3 4 5A 5B 5C 6A 6B 6C 7 8 9 10 11 12 13 14A 14B 15 16 17 18 19 20 21 22 23

RN-010-8-0-KB09-2L2:A000-C00-DTD-B00-00EA00E-00-00C0000VB
Tag: RTU-1,7-VS

Job Name:
Job Number:

SAPULPA POLICE DEPARTMENT
SPD

Unit Submittal For:
Unit Submittal Date:

March 16, 2020

	Base Option	Description
R	Series	Roof Top Unit
N	Generation	Ninth Generation
010	Unit Size	Ten
8	Voltage	208V/3Ø/60Hz
0	Interior Protection	Standard
K	Refrigerant Style	R-410A Variable Speed Scroll Compressor - High Efficiency
B	Unit Configuration	Air-Cooled Cond. + 6 Row Evap. Coil
0	Coil Coating	Standard
9	Cooling/Heat Pump Staging	Modulating - 1 Variable Capacity Compressor
2	Heating Type	Natural Gas Aluminized
L	Heating Designation	Heat L - 210 MBtuh
2	Heating Staging	2 Stage

	Feature Option	Description
A	1A. RA/OA Section	Economizer
0	1B. RA/EA Blower Configuration	Standard - None
0	1C. RA/EA Blower	Standard - None
0	1D. RA/EA Blower Motor	Standard - None
C	2. OA Control	Fully Modulating Actuator - Sensible Limit
0	3. Heat Options	Standard
0	4. Maintenance Options	Standard
D	5A. SA Blower Configuration	1 Blower + Premium Efficiency Motor + 1 VFD
T	5B. SA Blower	17" Direct Drive Backward Curved Plenum
D	5C. SA Motor	2.0 hp - 1760 rpm
B	6A. Pre Filter Type	Metal Mesh OA Pre Filter
0	6B. Unit Filter Type	2" Pleated - 30% Eff
0	6C. Filter Options	Standard
0	7. Refrigeration Control	Standard - Adj Comp. Cooling Lock Out Through Unit Controls
0	8. Refrigeration Options	Standard
E	9. Refrigeration Accessories	ECM Condenser Fan - Head Pressure Control
A	10. Power Options	Non-fused Disconnect Power Switch - 100 Amps
0	11. Safety Options	Standard
0	12. Controls	Standard
E	13. Special Controls	Constant Volume (CV) Unit Controller - CV Cool + CV Heat
0	14A. Outside Air Configuration	Standard - None
0	14B. Preheat Sizing	Standard - None
0	15. Glycol Percent	Water or No WSHP
0	16. Interior Cabinet Options	Standard - Double Wall + R-13 Foam Insulation + Stainless Steel Drain Pan
C	17. Exterior Cabinet Options	Cond. Coil Guards
0	18. Customer Code	Standard
0	19. Code Options	Standard - ETL U.S.A. Listing
0	20. Crating	Standard
0	21. Water-Cooled Cond.	Standard - None
V	22. Control Vendors	VCC-X Controls + Integrated BACnet MSTP
B	23. Type	Standard - Includes AAON Gray Paint



VCCX Components

2425 South Yukon Ave - Tulsa, Oklahoma 74107-2728 - Ph. (918) 583-2266 Fax (918) 583-6094
 AAONEcat32 Ver. 4.292 (SN: 6303792-)

1A 1B 1C 1D 2 3 4 5A 5B 5C 6A 6B 6C 7 8 9 10 11 12 13 14A 14B 15 16 17 18 19 20 21 22 23

RN-010-8-0-KB09-2L2:A000-C00-DTD-B00-00EA00E-00-00C0000VB

Tag: RTU-1,7-VS

Job Name: **SAPULPA POLICE DEPARTMENT**

VCCX For:

Job Number: **SPD**

VCCX Date:

March 16, 2020

Hardware Included For VCCX Controller

Part #	Included Parts	Assigned Channel	BACnet Point
ASM01698	VCCX2 CONTROLLER		
P94320	Space Temp Sensor	VCCX control point AI 1	AI:12
P94320	Space Temp Slide Adjust	VCCX control point AI 2	AI:8
R82890	Supply Temp Sensor - Field Installed	VCCX control point AI 3	AI:9
R81550	Outside Temp Sensor	VCCX control point AI 7	AI:16
	Supply Fan Control Signal 0-10VDC	VCCX control point AO 1	AI:22
	Economizer	VCCX control point AO 2	AI:30
R62330	Proof of Air Flow	VCCX control point BI 1	BI:6
	Safety Shut Down	VCCX control point BI 8	BI:26
	Supply Fan	Configured Relay point	BI:47
	Heat 1	Configured Relay Point	BI:48
	Heat 2	Configured Relay Point	BI:49

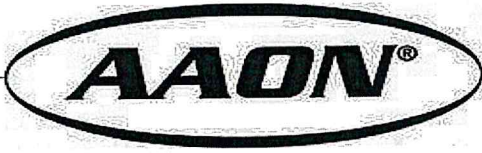

17.0" STAR Plenum

2425 South Yukon Ave - Tulsa, Oklahoma 74107-2728 - Ph. (918) 583-2266 Fax (918) 583-6094
AAONEcat32 Ver. 4.292 (SN: 6303792-)

JOB INFORMATION:

Job Name: *SAPULPA POLICE*
Job Tag: *DEPARTMENT*
Rep Firm: *RTU-1,7-VS*
Date: *04/02/2020*

WHEEL SPECIFICATION:

Max RPM: *2,400*
Diameter x Qty: *17.0 in. x 1*
CFM: *3000*
Tip Speed: *8,038 FPM*
Inertia: *3 WR²*

OPERATING CONDITIONS:

Air Flow: *3,000 CFM*
Static Pressure: *1.85 in. Wg.*
Relief Dampers DP: *0.00 in. Wg.*

TSP: *1.85 in. Wg.*
Site Altitude: *715.00 Ft*
TSP @ Sea Level: *1.90 in. Wg.*

MOTOR SELECTION:

Rated HP / Bypass: *2 / No*
Frame Size: *145T*
Nominal RPM: *1760*
VAC/PH/HZ: *208/3/60*
Efficiency: *Premium / 0.865*
Enclosure Type: *ODP*
Max Inertial Load: *27 WR²*

FAN PERFORMANCE:

RPM: *1806*
BHP: *1.67*
Efficiency: *52.3%*
In/Out Velocity: *2041/2128 FPM*
Plenum Out Velocity: *50 FPM*

FAN SOUND POWER (Inlet/Outlet):

Octave Band:	(Re 10 ⁻¹² watts)							
	1	2	3	4	5	6	7	8
	82	80	84	82	75	73	71	65
	82	80	84	82	75	73	71	65

SOUND POWER A-Weighted: 84 / 84 dB

Max Duct SP with Blocked Airway: *3.2 in. Wg. @ 1806 rpm*

Supply Fan Model: RN170 @ 1806 RPM and 100% Width
Design Conditions: 3000 CFM @ 1.90" SP

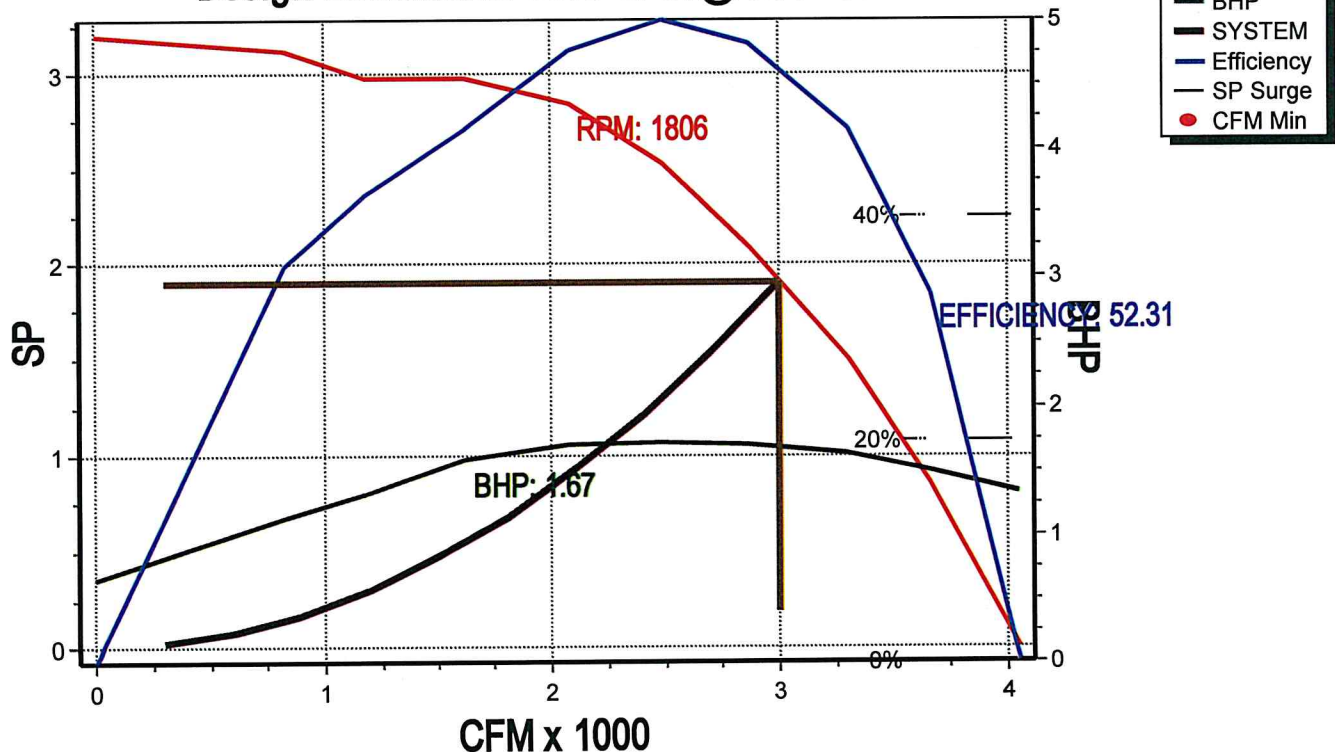

RN SERIES A - CABINET ECONOMIZER ~ 6-10 TON

CLEARANCES	
LOCATION	• UNIT SIZE • 6 - 10 TON
OUTSIDE AIR (BACK)	36
CONTROLS SIDE (FRONT)	48
LEFT SIDE	6
RIGHT SIDE	48
TOP	UNOBSTRUCTED

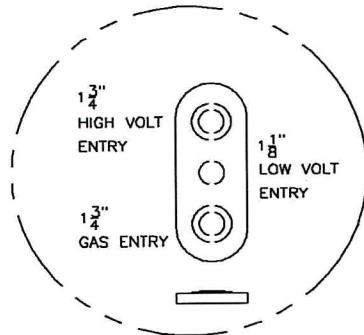

DETAIL A

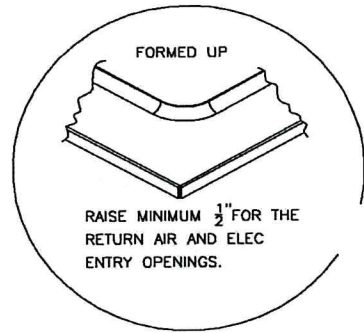

DETAIL B

NOTE: THE RNA UNIT IS NOT COMPATIBLE WITH PREVIOUS GENERATIONS OF AAO CURBS. AN ADAPTER CURB IS AVAILABLE IN ECAT.

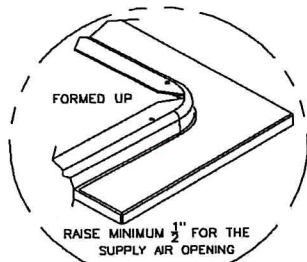

DETAIL C

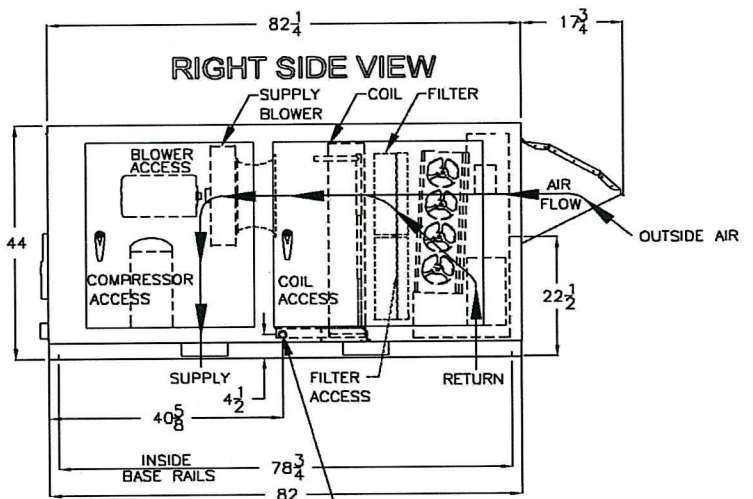
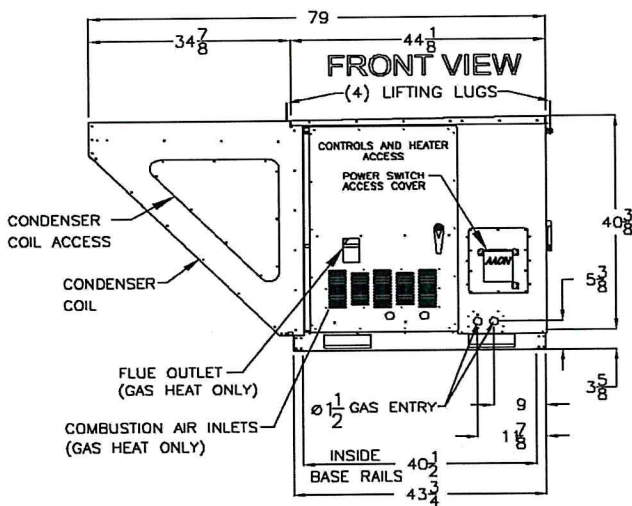
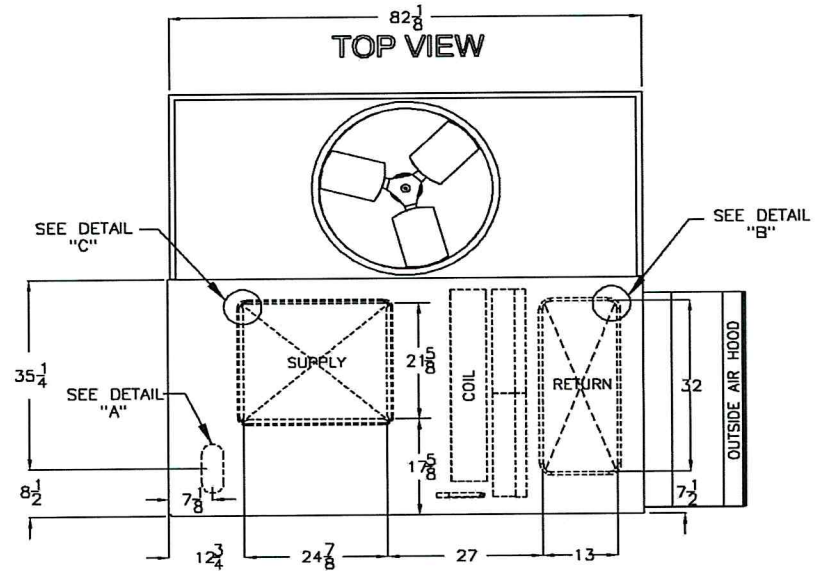

1" MPT STAINLESS CONDENSATE CONNECTION. "P" TRAP FURNISHED BY MANUFACTURER FOR DRAIN CONNECTION.

RNA-00013 NEW 09/15/09 JRL

NOTE: ALL DIMENSIONS ARE IN INCHES

RNA CABINET AIR COOLED CONDENSING UNIT



RN-010-8-0-KB09-2L2:A000-C00-DTD-B00-00EA00E-00-00C00000VB

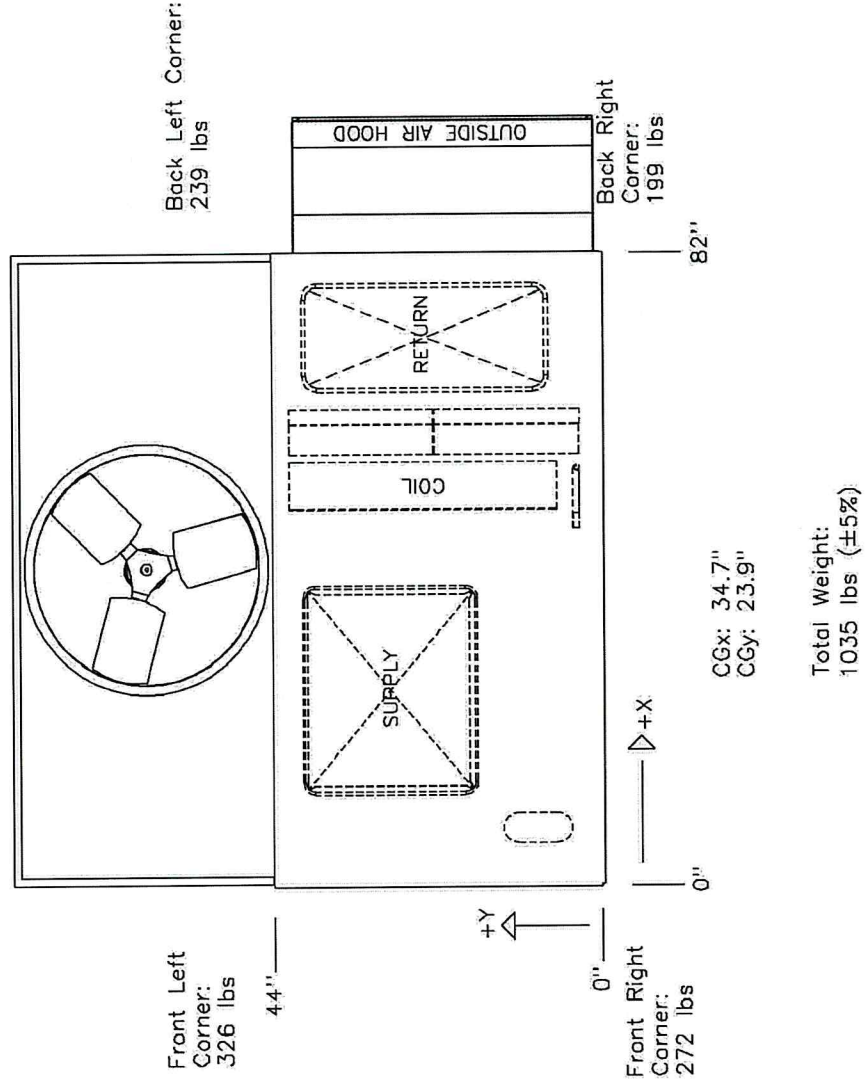

Disclaimer:
This weight estimate does not account for any SPAs.



Unit Rating

2425 South Yukon Ave - Tulsa, Oklahoma 74107-2728 - Ph. (918) 583-2266 Fax (918) 583-6094
AAONEcat32 Ver. 4.292 (SN: 6303792-)

1A 1B 1C 1D 2 3 4 5A 5B 5C 6A 6B 6C 7 8 9 10 11 12 13 14A 14B 15 16 17 18 19 20 21 22 23

RQ-004-8-V-KA09-231:A000-C00-QJC-B00-00EA002-00-0000000VB
Tag: RTU-2,8-VS

Job Information

Job Name: *SAPULPA POLICE DEPARTMENT*
 Job Number: *SPD*
 Site Altitude: *715 ft*
 Refrigerant: *R-410A*

Unit Information

Approx. Op./Ship Weights: *651 / 651 lbs. (±5%)*
 Supply CFM/ESP: *1600 / 0.55 in. wg.*
 Final Filter FV / Qty: *288.00 fpm / 2*
 Outside CFM: *480*
 Ambient Temperature: *100 °F DB / 78 °F WB*
 Return Temperature: *72 °F DB / 59 °F WB*

Static Pressure

External: *0.55 in. wg.*
 Evaporator: *0.22 in. wg.*
 Filters Clean: *0.11 in. wg.*
 Dirt Allowance: *0.35 in. wg.*

Economizer: *0.10 in. wg.*
 Heating: *0.14 in. wg.*
 Cabinet: *0.06 in. wg.*
 Total: *1.52 in. wg.*

Cooling Section

	Gross	Net
Total Capacity:	<i>48.16</i>	<i>45.82 MBH</i>
Sensible Capacity:	<i>40.59</i>	<i>38.25 MBH</i>
Latent Capacity:	<i>7.57 MBH</i>	
Mixed Air Temp:	<i>80.40 °F DB</i>	<i>65.57 °F WB</i>
Entering Air Temp:	<i>80.40 °F DB</i>	<i>65.57 °F WB</i>
Lv Air Temp (Coil):	<i>55.81 °F DB</i>	<i>55.24 °F WB</i>
Lv Air Temp (Unit):	<i>57.18 °F DB</i>	<i>55.78 °F WB</i>
Supply Air Fan:	<i>1 x RQ185-VFD @ 0.72 BHP</i>	
SA Fan RPM / Width:	<i>1373 / 3.000"</i>	
Evaporator Coil:	<i>5.3 ft² / 4 Rows / 14 FPI</i>	
Evaporator Face Velocity:	<i>304.8 fpm</i>	

Heating Section

PreHeat Type: *Std (No Preheat)*
 Heating Type: *Nat. Gas Heat*
 Heating CFM: *1600*
 Total Capacity: *81.0 MBH*
 OA Temp: *13.0 DB / 12.0 °F WB*
 RA Temp: *72.0 °F DB / 59.0 °F WB*
 Entering Air Temp: *54.3 °F DB / 48.2 °F WB*
 Leaving Air Temp: *101.2 °F DB / 66.2 °F WB*
 Input: *100.0 MBH*
 Heater Qty (Hi/Low): *1*
 Consumption: *100.0 MBH*
 Operation: *N/A*

Rating Information

Cooling Capacity (MBH): *52.0*
 Cooling SEER: *19.2*
 Cooling EER: *12.9*
Rated in accordance with AHRI 210/240

Application EER @ Op. Conditions: *9.7*

Electrical Data

Rating: *208/3/60*
 Unit FLA: *19*

Minimum Circuit Amp: *22*
 Maximum Overcurrent: *30*

	Qty	HP	VAC	Phase	RPM	FLA	RLA
Compressor 1:	1		208	3			12
Condenser Fans:	1	0.333	208	1	1110	2.8	
Supply Fan:	1	1.00	208	3	1760	4.6	
Combustion:	1	0.09	208	1	3000	1.3	

Cabinet Sound Power Levels*

Octave Bands:	63	125	250	500	1000	2000	4000	8000
Discharge LW(dB):	80	80	81	75	68	66	63	58
Return LW(dB):	76	75	71	62	60	58	53	45

*Sound power levels are given for informational purposes only. The sound levels are not guaranteed.



Unit Submittal

2425 South Yukon Ave - Tulsa, Oklahoma 74107-2728 - Ph. (918) 583-2266 Fax (918) 583-6094
AAONEcat32 Ver. 4.292 (SN: 6303792-)

1A 1B 1C 1D 2 3 4 5A 5B 5C 6A 6B 6C 7 8 9 10 11 12 13 14A 14B 15 16 17 18 19 20 21 22 23

RQ-004-8-V-KA09-231:A000-C00-QJC-B00-00EA002-00-0000000VB
Tag: RTU-2,8-VS

Job Name:
Job Number:

SAPULPA POLICE DEPARTMENT
SPD

Unit Submittal For:
Unit Submittal Date:

March 16, 2020

	Base Option	Description
R	Series	Roof Top Unit
Q	Generation	Tenth Generation
004	Unit Size	Four
8	Voltage	208V/3Ø/60Hz
V	Interior Protection	Vertical Discharge and Return
K	Refrigerant Style	R-410A Variable Speed Scroll Compressor - High Efficiency
A	Unit Configuration	Air-Cooled Cond. + Std Evap. Coil
0	Coil Coating	Standard
9	Cooling/Heat Pump Staging	1 Variable Speed Compressor
2	Heating Type	Natural Gas Aluminized
3	Heating Designation	Heat 3 - 100 MBtuh
1	Heating Staging	1 Stage

	Feature Option	Description
A	1A. RA/OA Section	Economizer
0	1B. RA/EA Blower Configuration	Standard - None
0	1C. RA/EA Blower	Standard - None
0	1D. RA/EA Blower Motor	Standard - None
C	2. OA Control	Fully Modulating Actuator - Sensible Limit
0	3. Heat Options	Standard
0	4. Maintenance Options	Standard
Q	5A. SA Blower Configuration	1 Blower + Inverter Rated 3 Phase Motor + VFD
J	5B. SA Blower	19" Direct Drive Backward Curved Plenum
C	5C. SA Motor	1 HP 1750 rpm
B	6A. Pre Filter Type	Metal Mesh OA Pre Filter
0	6B. Unit Filter Type	2" Pleated - MERV 8
0	6C. Filter Options	Standard
0	7. Refrigeration Control	Standard - Adj Comp. Cooling Lock Out Through Unit Controls
0	8. Refrigeration Options	Standard
E	9. Refrigeration Accessories	ECM Condenser Fan - Head Pressure Control
A	10. Power Options	Non-fused Disconnect Power Switch - 100 Amps
0	11. Safety Options	Standard
0	12. Controls	Standard
2	13. Special Controls	VAV Single Zone Unit Controller - VAV Cool + CAV Heat
0	14A. Preheat Configuration	Standard - None
0	14B. Preheat Sizing	Standard - None
0	15. Glycol Percent	Water or No WSHP
0	16. Interior Cabinet Options	Standard - Double Wall + R-13 Foam Insulation + Stainless Steel Drain Pan
0	17. Exterior Cabinet Options	Standard
0	18. Customer Code	Standard
0	19. Code Options	Standard - ETL U.S.A. Listing
0	20. Crating	Standard
0	21. Water-Cooled Cond.	Standard - None
V	22. Control Vendors	VCCX w/ BACnet MSTP
B	23. Type	Standard - Includes AAON Gray Paint



VCCX Components

2425 South Yukon Ave - Tulsa, Oklahoma 74107-2728 - Ph. (918) 583-2266 Fax (918) 583-6094
AAONEcat32 Ver. 4.292 (SN: 6303792-)

1A 1B 1C 1D 2 3 4 5A 5B 5C 6A 6B 6C 7 8 9 10 11 12 13 14A 14B 15 16 17 18 19 20 21 22 23

RQ-004-8-V-KA09-231:A000-C00-QJC-B00-00EA002-00-0000000VB

Tag: RTU-2,8-VS

Job Name: **SAPULPA POLICE
DEPARTMENT**

VCCX For:

Job Number: **SPD**

VCCX Date: **March 16, 2020**

Hardware Included For VCCX Controller

Part #	Included Parts	Assigned Channel	BACnet Point
ASM01698	VCCX2 CONTROLLER		
P94320	Space Temp Sensor	VCCX control point AI 1	AI:12
P94320	Space Temp Slide Adjust	VCCX control point AI 2	AI:8
R82890	Supply Temp Sensor - Field Installed	VCCX control point AI 3	AI:9
R81550	Outside Temp Sensor	VCCX control point AI 7	AI:16
	Supply Fan Control Signal 0-10VDC	VCCX control point AO 1	AI:22
	Economizer	VCCX control point AO 2	AI:30
R62330	Proof of Air Flow	VCCX control point BI 1	BI:6
	Safety Shut Down	VCCX control point BI 8	BI:26
	Supply Fan	Configured Relay point	BI:47
	Heat 1	Configured Relay Point	BI:48
ASM01686	REFRIGERATION MODULE		
V38391	Suction Pressure Sensor	RSMV 1 point AI 1	AI:48
V38410	Discharge Pressure Sensor	RSMV 1 point AI 2	AI:50
	Modulated Condenser Signal	RSMV 1 point AO2	AI:46
	Comp Status Input 1	RSMV 1 point BI 1	BI:79
	Comp Enable 1	RSMV 1 Fixed Relay point	BI:77, BI:84



18.5" STAR Plenum

2425 South Yukon Ave - Tulsa, Oklahoma 74107-2728 - Ph. (918) 583-2266 Fax (918) 583-6094
AAONEcat32 Ver. 4.292 (SN: 6303792-)

JOB INFORMATION:

Job Name: *SAPULPA POLICE*
 Job Tag: *DEPARTMENT*
 Rep Firm: *RTU-2,8-VS*
 Date: *04/02/2020*
04/02/2020

WHEEL SPECIFICATION:

Max RPM: *2,200*
 Diameter x Qty: *18.5 in. x 1*
 CFM: *1600*
 Tip Speed: *1600*
 Inertia: *6,650 FPM*
6,650 FPM

OPERATING CONDITIONS:

Air Flow: *1,600 CFM*
 Static Pressure: *1.52 in. Wg.*
 Relief Dampers DP: *0.00 in. Wg.*
 TSP: *1.52 in. Wg.*
 Site Altitude: *715.00 Ft*
 TSP @ Sea Level: *1.56 in. Wg.*

MOTOR SELECTION:

Rated HP / Bypass: *1 / No*
 Frame Size: *48*
 Nominal RPM: *1760*
 VAC/PH/HZ: *208/3/60*
 Efficiency: *Standard / 0.785*
 Enclosure Type: *ODP*
 Max Inertial Load: *15 WR²*

FAN PERFORMANCE:

RPM: *1373*
 BHP: *0.72*
 Efficiency: *53.0%*
 In/Out Velocity: */ FPM*
 Plenum Out Velocity: *27 FPM*

FAN SOUND POWER (Inlet/Outlet):

Octave Band:		(Re 10 ⁻¹² watts)							
1	2	3	4	5	6	7	8		
80	80	81	77	72	70	67	62		
80	80	81	77	72	70	67	62		

SOUND POWER A-Weighted: *81 / 81 dB*

Max Duct SP with Blocked Airway: *2.1 in. Wg. @ 1373 rpm*

Supply Fan Model: RQ185-VFD @ 1373 RPM and 100% Width
 Design Conditions: 1600 CFM @ 1.56" SP

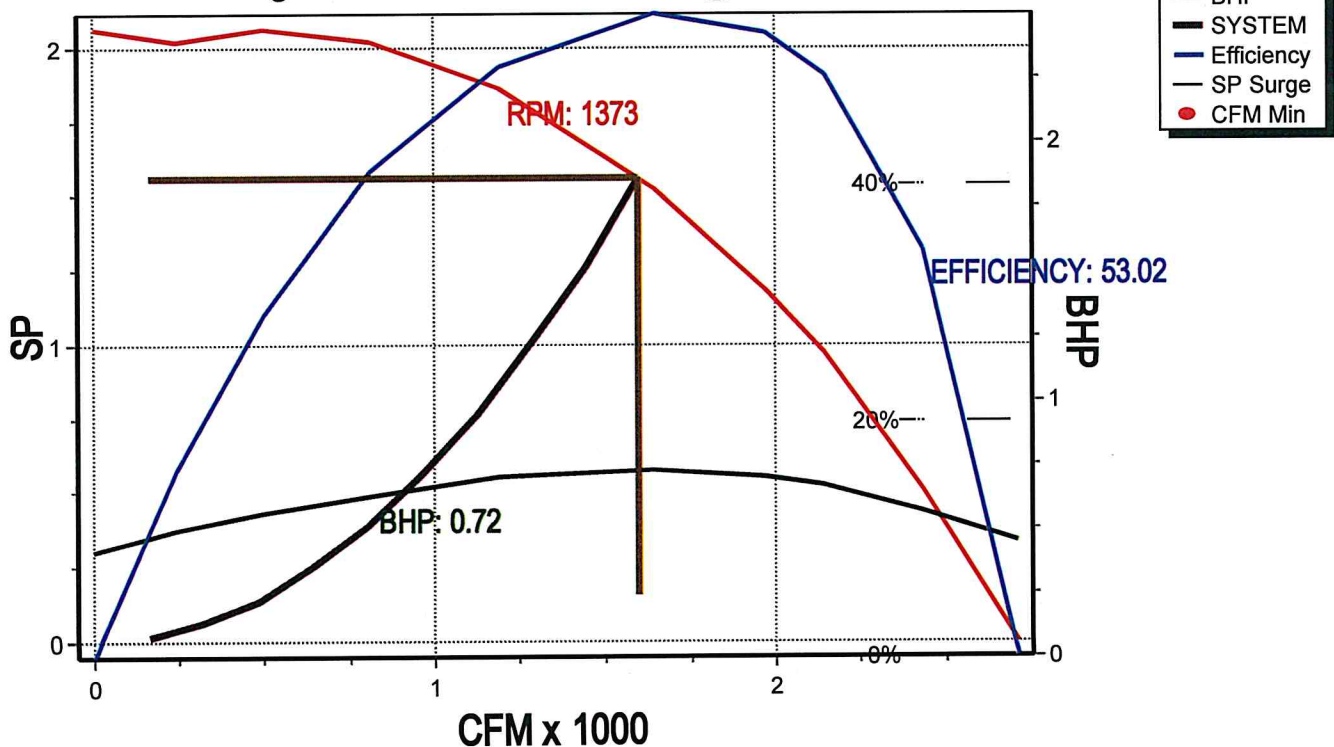

RQ CABINET ECONOMIZER VERTICAL ~ 1-6 TON

CLEARANCES	
LOCATION	UNIT SIZE
	1-6 TON
OUTSIDE AIR (BACK)	36*
HXC (FRONT)	36
LEFT SIDE	24
RIGHT SIDE	48
TOP	UNOBSTRUCTED

*CLEARANCE IS MEASURED FROM THE END OF THE OUTSIDE AIR RAIN HOOD

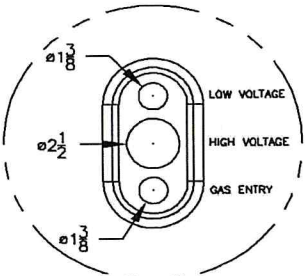

DETAIL A

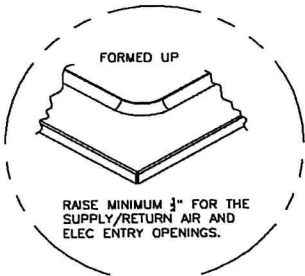

DETAIL B

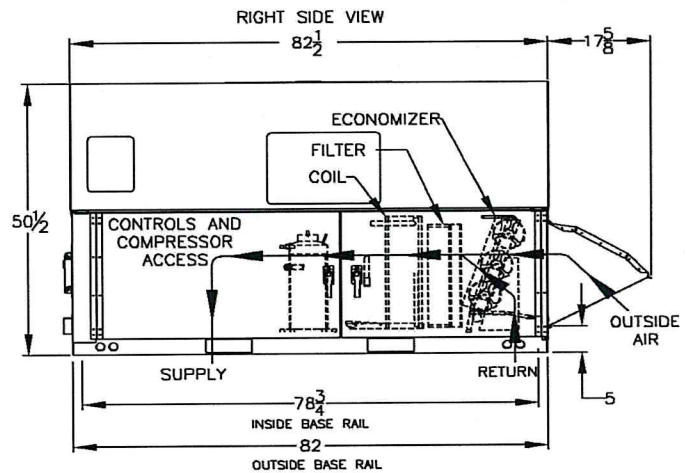
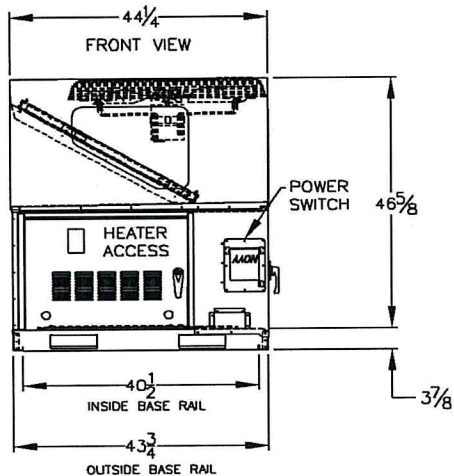
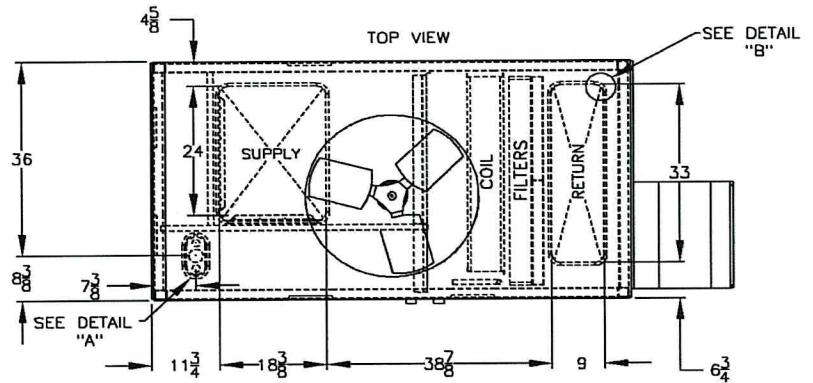
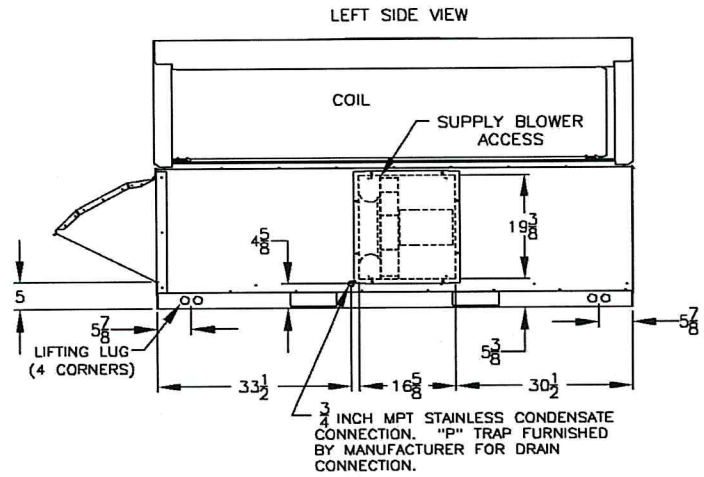

RQ CABINET
 VERTICAL AIR COOLED CONDENSING UNIT



RQ-004-8-V-KA09-231:A000-C00-QJC-B00-00EA002-00-00000000VB

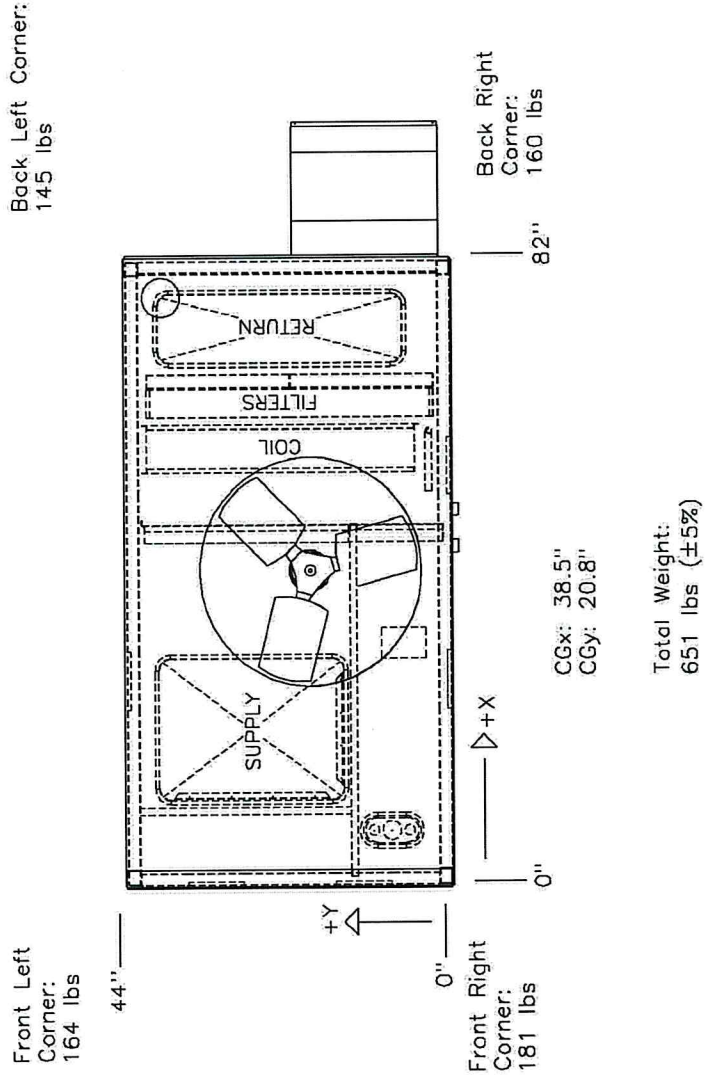

Disclaimer:
 This weight estimate does not account for any SPAs.

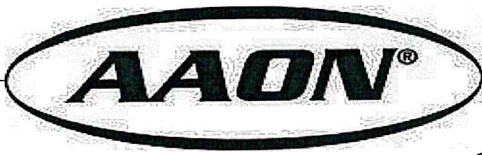

Unit Rating

2425 South Yukon Ave - Tulsa, Oklahoma 74107-2728 - Ph. (918) 583-2266 Fax (918) 583-6094
AAONEcat32 Ver. 4.292 (SN: 6303792-)

1A 1B 1C 1D 2 3 4 5A 5B 5C 6A 6B 6C 7 8 9 10 11 12 13 14A 14B 15 16 17 18 19 20 21 22 23

RQ-003-8-V-KA09-231:A000-C00-QJC-B00-00EA002-00-0000000VB

Tag: RTU-3-VS

Job Information

Job Name: *SAPULPA POLICE DEPARTMENT*
 Job Number: *SPD*
 Site Altitude: *715 ft*
 Refrigerant: *R-410A*

Unit Information

Approx. Op./Ship Weights: *651 / 651 lbs. (±5%)*
 Supply CFM/ESP: *1200 / 0.55 in. wg.*
 Final Filter FV / Qty: *216.00 fpm / 2*
 Outside CFM: *360*
 Ambient Temperature: *100 °F DB / 73 °F WB*
 Return Temperature: *72 °F DB / 59 °F WB*

Static Pressure

External: *0.55 in. wg.*
 Evaporator: *0.11 in. wg.*
 Filters Clean: *0.08 in. wg.*
 Dirt Allowance: *0.35 in. wg.*

Economizer: *0.12 in. wg.*
 Heating: *0.08 in. wg.*
 Cabinet: *0.03 in. wg.*
 Total: *1.33 in. wg.*

Cooling Section

	Gross	Net
Total Capacity:	<i>39.52</i>	<i>37.93 MBH</i>
Sensible Capacity:	<i>31.47</i>	<i>29.88 MBH</i>
Latent Capacity:	<i>8.05 MBH</i>	
Mixed Air Temp:	<i>80.40 °F DB</i>	<i>65.57 °F WB</i>
Entering Air Temp:	<i>80.40 °F DB</i>	<i>65.57 °F WB</i>
Lv Air Temp (Coil):	<i>54.97 °F DB</i>	<i>54.15 °F WB</i>
Lv Air Temp (Unit):	<i>56.22 °F DB</i>	<i>54.65 °F WB</i>
Supply Air Fan:	<i>1 x RQ185-VFD @ 0.49 BHP</i>	
SA Fan RPM / Width:	<i>1215 / 3.000"</i>	
Evaporator Coil:	<i>5.3 ft² / 3 Rows / 14 FPI</i>	
Evaporator Face Velocity:	<i>228.6 fpm</i>	

Heating Section

PreHeat Type: *Std (No Preheat)*
 Heating Type: *Nat. Gas Heat*
 Heating CFM: *1200*
 Total Capacity: *81.0 MBH*
 OA Temp: *13.0 DB / 12.0 °F WB*
 RA Temp: *72.0 °F DB / 59.0 °F WB*
 Entering Air Temp: *54.3 °F DB / 48.2 °F WB*
 Leaving Air Temp: *116.3 °F DB / 70.9 °F WB*
 Input: *100.0 MBH*
 Heater Qty (Hi/Low): *1*
 Consumption: *100.0 MBH*
 Operation: *N/A*

Rating Information

Cooling Capacity (MBH): *41.0*
 Cooling SEER: *20.7*
 Cooling EER: *12.2*
Rated in accordance with AHRI 210/240

Application EER @ Op. Conditions: *10.2*

Electrical Data

Rating: *208/3/60*
 Unit FLA: *16*

Minimum Circuit Amp: *19*
 Maximum Overcurrent: *25*

	Qty	HP	VAC	Phase	RPM	FLA	RLA
Compressor 1:	1		208	3			9
Condenser Fans:	1	0.333	208	1	1110	2.8	
Supply Fan:	1	1.00	208	3	1760	4.6	
Combustion:	1	0.09	208	1	3000	1.3	

Cabinet Sound Power Levels*

Octave Bands:	63	125	250	500	1000	2000	4000	8000
Discharge LW(dB):	77	78	77	71	65	63	60	54
Return LW(dB):	74	74	68	59	58	56	50	42

*Sound power levels are given for informational purposes only. The sound levels are not guaranteed.



Unit Submittal

2425 South Yukon Ave - Tulsa, Oklahoma 74107-2728 - Ph. (918) 583-2266 Fax (918) 583-6094
AAONEcat32 Ver. 4.292 (SN: 6303792-)

1A 1B 1C 1D 2 3 4 5A 5B 5C 6A 6B 6C 7 8 9 10 11 12 13 14A 14B 15 16 17 18 19 20 21 22 23

RQ-003-8-V-KA09-231:A000-C00-QJC-B00-00EA002-00-0000000VB
Tag: RTU-3-VS

Job Name:
Job Number:

SAPULPA POLICE DEPARTMENT
SPD

Unit Submittal For:
Unit Submittal Date:

March 16, 2020

	Base Option	Description
R	Series	Roof Top Unit
Q	Generation	Tenth Generation
003	Unit Size	Three
8	Voltage	208V/3Ø/60Hz
V	Interior Protection	Vertical Discharge and Return
K	Refrigerant Style	R-410A Variable Speed Scroll Compressor - High Efficiency
A	Unit Configuration	Air-Cooled Cond. + Std Evap. Coil
0	Coil Coating	Standard
9	Cooling/Heat Pump Staging	1 Variable Speed Compressor
2	Heating Type	Natural Gas Aluminized
3	Heating Designation	Heat 3 - 100 MBtuh
1	Heating Staging	1 Stage

	Feature Option	Description
A	1A. RA/OA Section	Economizer
0	1B. RA/EA Blower Configuration	Standard - None
0	1C. RA/EA Blower	Standard - None
0	1D. RA/EA Blower Motor	Standard - None
C	2. OA Control	Fully Modulating Actuator - Sensible Limit
0	3. Heat Options	Standard
0	4. Maintenance Options	Standard
Q	5A. SA Blower Configuration	1 Blower + Inverter Rated 3 Phase Motor + VFD
J	5B. SA Blower	19" Direct Drive Backward Curved Plenum
C	5C. SA Motor	1 HP 1750 rpm
B	6A. Pre Filter Type	Metal Mesh OA Pre Filter
0	6B. Unit Filter Type	2" Pleated - MERV 8
0	6C. Filter Options	Standard
0	7. Refrigeration Control	Standard - Adj Comp. Cooling Lock Out Through Unit Controls
0	8. Refrigeration Options	Standard
E	9. Refrigeration Accessories	ECM Condenser Fan - Head Pressure Control
A	10. Power Options	Non-fused Disconnect Power Switch - 100 Amps
0	11. Safety Options	Standard
0	12. Controls	Standard
2	13. Special Controls	VAV Single Zone Unit Controller - VAV Cool + CAV Heat
0	14A. Preheat Configuration	Standard - None
0	14B. Preheat Sizing	Standard - None
0	15. Glycol Percent	Water or No WSHP
0	16. Interior Cabinet Options	Standard - Double Wall + R-13 Foam Insulation + Stainless Steel Drain Pan
0	17. Exterior Cabinet Options	Standard
0	18. Customer Code	Standard
0	19. Code Options	Standard - ETL U.S.A. Listing
0	20. Crating	Standard
0	21. Water-Cooled Cond.	Standard - None
V	22. Control Vendors	VCCX w/ BACnet MSTP
B	23. Type	Standard - Includes AAON Gray Paint

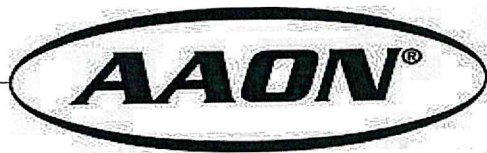

VCCX Components

2425 South Yukon Ave - Tulsa, Oklahoma 74107-2728 - Ph. (918) 583-2266 Fax (918) 583-6094
AAONEcat32 Ver. 4.292 (SN: 6303792-)

1A 1B 1C 1D 2 3 4 5A 5B 5C 6A 6B 6C 7 8 9 10 11 12 13 14A 14B 15 16 17 18 19 20 21 22 23

RQ-003-8-V-KA09-231:A000-C00-QJC-B00-00EA002-00-0000000VB

Tag: RTU-3-VS

Job Name:

**SAPULPA POLICE
DEPARTMENT**

VCCX For:

Job Number:

SPD

VCCX Date:

March 16, 2020

Hardware Included For VCCX Controller

Part #	Included Parts	Assigned Channel	BACnet Point
ASM01698	VCCX2 CONTROLLER		
P94320	Space Temp Sensor	VCCX control point AI 1	AI:12
P94320	Space Temp Slide Adjust	VCCX control point AI 2	AI:8
R82890	Supply Temp Sensor - Field Installed	VCCX control point AI 3	AI:9
R81550	Outside Temp Sensor	VCCX control point AI 7	AI:16
	Supply Fan Control Signal 0-10VDC	VCCX control point AO 1	AI:22
	Economizer	VCCX control point AO 2	AI:30
R62330	Proof of Air Flow	VCCX control point BI 1	BI:6
	Safety Shut Down	VCCX control point BI 8	BI:26
	Supply Fan	Configured Relay point	BI:47
	Heat 1	Configured Relay Point	BI:48
ASM01686	REFRIGERATION MODULE		
V38391	Suction Pressure Sensor	RSMV 1 point AI 1	AI:48
V38410	Discharge Pressure Sensor	RSMV 1 point AI 2	AI:50
	Modulated Condenser Signal	RSMV 1 point AO2	AI:46
	Comp Status Input 1	RSMV 1 point BI 1	BI:79
	Comp Enable 1	RSMV 1 Fixed Relay point	BI:77,BI:84

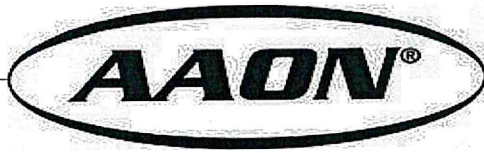

18.5" STAR Plenum

2425 South Yukon Ave - Tulsa, Oklahoma 74107-2728 - Ph. (918) 583-2266 Fax (918) 583-6094
AAONEcat32 Ver. 4.292 (SN: 6303792-)

JOB INFORMATION:

Job Name: SAPULPA POLICE
 Job Tag: DEPARTMENT
 Rep Firm: RTU-3-VS
 Date: 04/02/2020
 04/02/2020

WHEEL SPECIFICATION:

Max RPM: 2,200
 Diameter x Qty: 18.5 in. x 1
 CFM: 1200
 Tip Speed: 5,885 FPM
 Inertia: 5,885 FPM

OPERATING CONDITIONS:

Air Flow: 1,200 CFM
 Static Pressure: 1.33 in. Wg.
 Relief Dampers DP: 0.00 in. Wg.
 TSP: 1.33 in. Wg.
 Site Altitude: 715.00 Ft
 TSP @ Sea Level: 1.37 in. Wg.

MOTOR SELECTION:

Rated HP / Bypass: 1 / No
 Frame Size: 48
 Nominal RPM: 1760
 VAC/PH/HZ: 208/3/60
 Efficiency: Standard / 0.785
 Enclosure Type: ODP
 Max Inertial Load: 15 WR²

FAN PERFORMANCE:

RPM: 1215
 BHP: 0.49
 Efficiency: 51.2%
 In/Out Velocity: / FPM
 Plenum Out Velocity: 20 FPM

FAN SOUND POWER (Inlet/Outlet):

Octave Band:	(Re 10 ⁻¹² watts)							
	1	2	3	4	5	6	7	8
	77	78	77	73	68	66	63	57
	77	78	77	73	68	66	63	57

SOUND POWER A-Weighted: 78 / 78 dB

Max Duct SP with Blocked Airway: 1.6 in. Wg. @ 1215 rpm

Supply Fan Model: RQ185-VFD @ 1215 RPM and 100% Width
 Design Conditions: 1200 CFM @ 1.37" SP

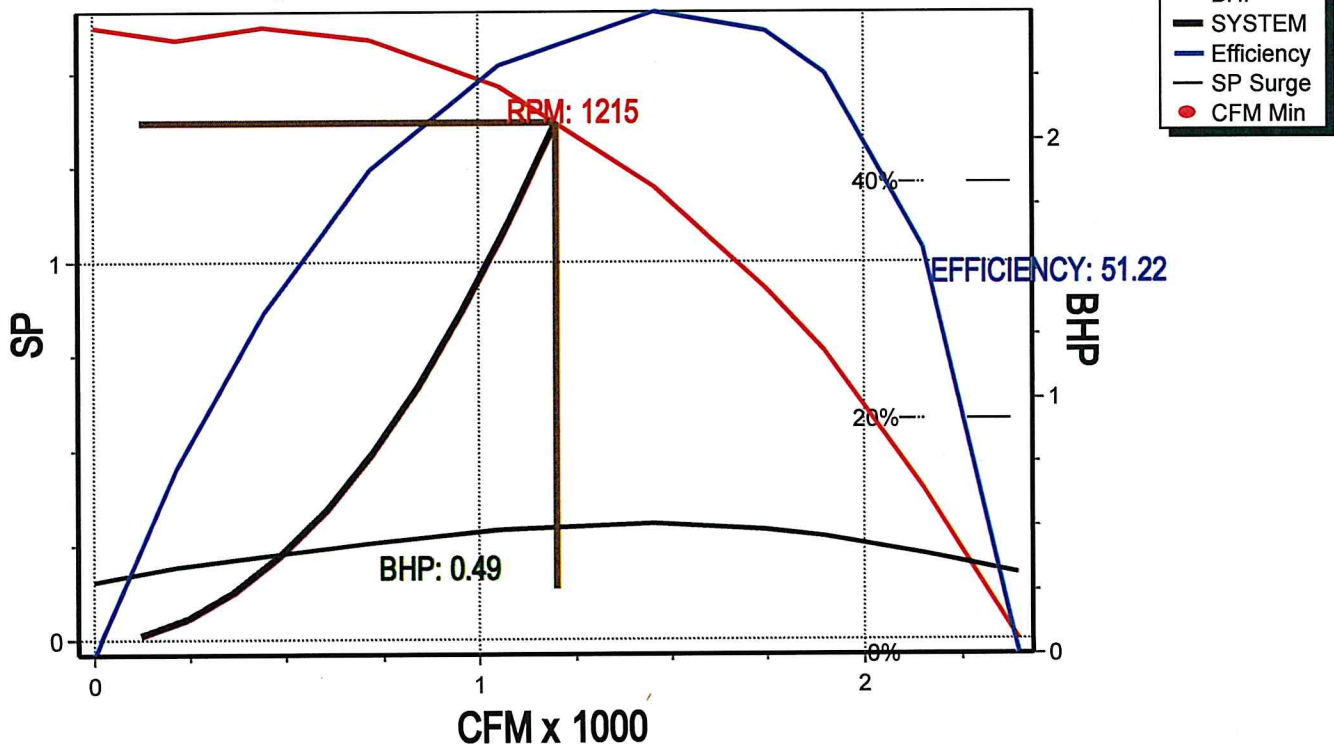

RQ CABINET ECONOMIZER VERTICAL ~ 1-6 TON

CLEARANCES	
LOCATION	• UNIT SIZE • 1-6 TON
OUTSIDE AIR (BACK)	36*
HXC (FRONT)	36
LEFT SIDE	24
RIGHT SIDE	48
TOP	UNOBSTRUCTED

***CLEARANCE IS MEASURED FROM THE END OF THE OUTSIDE AIR RAIN HOOD**

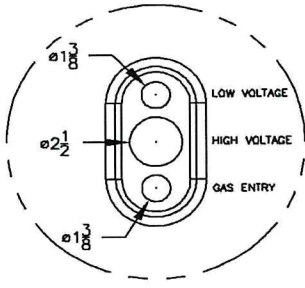

DETAIL A

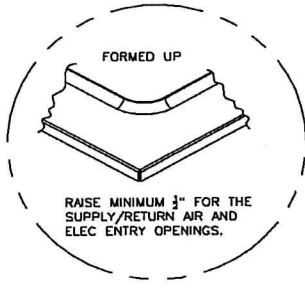

DETAIL B

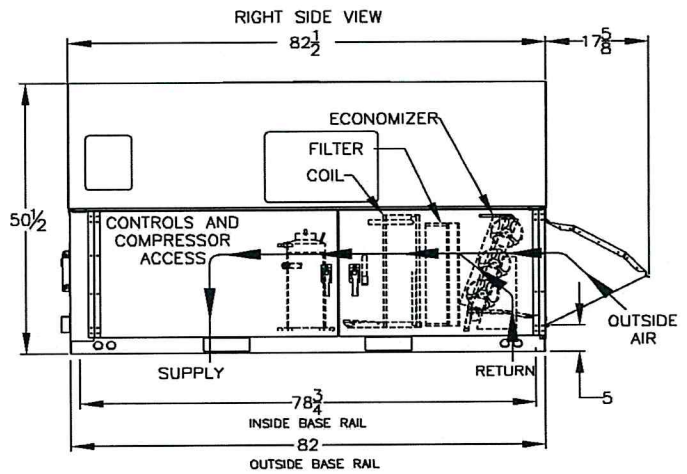
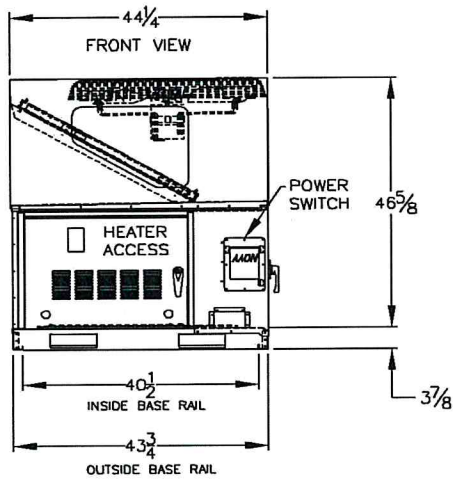
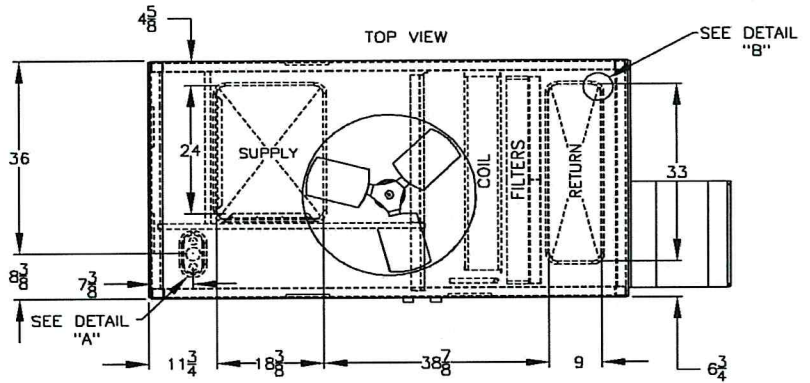
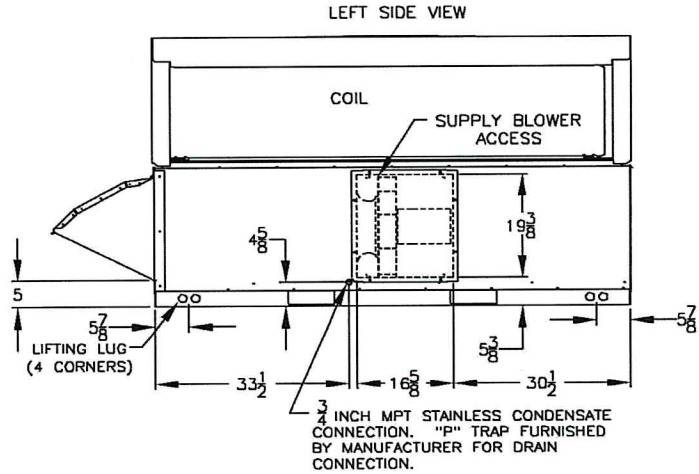

RQ CABINET VERTICAL AIR COOLED CONDENSING UNIT



RQ-003-8-V-KA09-231:A000-C00-QJC-B00-00EA002-00-00000000VB

Back Left Corner:
145 lbs

Front Left
Corner:
164 lbs

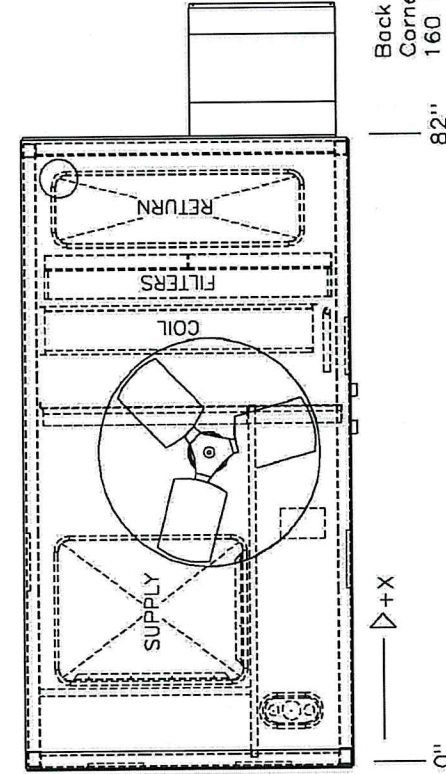

Front Right
Corner:
181 lbs

Back Right
Corner:
160 lbs

CGx: 38.5"
CGy: 20.8"

Total Weight:
651 lbs (±5%)

Disclaimer:
This weight estimate does not account for any SPAs.



Unit Rating

2425 South Yukon Ave - Tulsa, Oklahoma 74107-2728 - Ph. (918) 583-2266 Fax (918) 583-6094
AAONEcat32 Ver. 4.292 (SN: 6303792-)

1A 1B 1C 1D 2 3 4 5A 5B 5C 6A 6B 6C 7 8 9 10 11 12 13 14A 14B 15 16 17 18 19 20 21 22 23

RN-008-8-0-KB09-2L2:A000-C00-DTE-B00-00EB00E-00-00C0000VB
Tag: RTU-4VS

Job Information

Job Name: *SAPULPA POLICE DEPARTMENT*
Job Number: *SPD*
Site Altitude: *715 ft*
Refrigerant: *R-410A*

Unit Information

Approx. Op./Ship Weights: *1005 / 1005 lbs. (±5%)*
Supply CFM/ESP: *3400 / 0.6 in. wg.*
Final Filter FV / Qty: *382.50 fpm / 4*
Outside CFM: *1020*
Ambient Temperature: *100 °F DB / 78 °F WB*
Return Temperature: *72 °F DB / 59 °F WB*

Static Pressure

External: *0.60 in. wg.*
Evaporator: *0.46 in. wg.*
Filters Clean: *0.16 in. wg.*
Dirt Allowance: *0.35 in. wg.*

Economizer: *0.10 in. wg.*
Heating: *0.15 in. wg.*
Cabinet: *0.16 in. wg.*
Total: *1.98 in. wg.*

Cooling Section

	Gross	Net
Total Capacity:	<i>95.97</i>	<i>89.95 MBH</i>
Sensible Capacity:	<i>85.41</i>	<i>79.39 MBH</i>
Latent Capacity:	<i>10.56 MBH</i>	
Mixed Air Temp:	<i>80.40 °F DB</i>	<i>65.57 °F WB</i>
Entering Air Temp:	<i>80.40 °F DB</i>	<i>65.57 °F WB</i>
Lv Air Temp (Coil):	<i>56.06 °F DB</i>	<i>55.87 °F WB</i>
Lv Air Temp (Unit):	<i>57.72 °F DB</i>	<i>56.51 °F WB</i>
Supply Air Fan:	<i>1 x RN170 @ 2.12 BHP</i>	
SA Fan RPM / Width:	<i>1962 / 3.810"</i>	
Evaporator Coil:	<i>8.5 ft² / 6 Rows / 14 FPI</i>	
Evaporator Face Velocity:	<i>399.7 fpm</i>	

Heating Section

PreHeat Type: *Std (No Preheat)*
Heating Type: *Nat. Gas Heat*
Heating CFM: *3400*
Total Capacity: *168.0 MBH*
OA Temp: *13.0 °F DB / 12.0 °F WB*
RA Temp: *72.0 °F DB / 59.0 °F WB*
Entering Air Temp: *54.3 °F DB / 48.2 °F WB*
Leaving Air Temp: *100.0 °F DB / 65.8 °F WB*
Input: *210.0 MBH*
Heater Qty: *1*
Consumption: *210.0 MBH*
Total Turndown Ratio: *1.4:1*

Rating Information

Rated in accordance with AHRI 340/360

Application EER @ Op. Conditions: *9.6*

Electrical Data

Rating: *208/3/60*
Unit FLA: *62*

Minimum Circuit Amp: *73*
Maximum Overcurrent: *110*

	Qty	HP	VAC	Phase	RPM	FLA	RLA
Compressor 1:	1		208	3			44.2
Condenser Fans:	1	1.00	208	1	1110	7.0	
Supply Fan:	1	3.00	208	3	1760	10.6	
Combustion:	1	0.09	208	1	3010	1.3	

Cabinet Sound Power Levels*

Octave Bands:	63	125	250	500	1000	2000	4000	8000
Discharge LW(dB):	83	81	84	82	74	71	68	63
Return LW(dB):	73	73	71	65	61	56	51	41

*Sound power levels are given for informational purposes only. The sound levels are not guaranteed.



Unit Submittal

2425 South Yukon Ave - Tulsa, Oklahoma 74107-2728 - Ph. (918) 583-2266 Fax (918) 583-6094
AAONEcat32 Ver. 4.292 (SN: 6303792-)

1A 1B 1C 1D 2 3 4 5A 5B 5C 6A 6B 6C 7 8 9 10 11 12 13 14A 14B 15 16 17 18 19 20 21 22 23

RN-008-8-0-KB09-2L2:A000-C00-DTE-B00-00EB00E-00-00C0000VB
Tag: RTU-4-VS

Job Name:
Job Number:

SAPULPA POLICE DEPARTMENT
SPD

Unit Submittal For:
Unit Submittal Date:

March 16, 2020

	Base Option	Description
R	Series	Roof Top Unit
N	Generation	Ninth Generation
008	Unit Size	Eight
8	Voltage	208V/3Ø/60Hz
0	Interior Protection	Standard
K	Refrigerant Style	R-410A Variable Speed Scroll Compressor - High Efficiency
B	Unit Configuration	Air-Cooled Cond. + 6 Row Evap. Coil
0	Coil Coating	Standard
9	Cooling/Heat Pump Staging	Modulating - 1 Variable Capacity Compressor
2	Heating Type	Natural Gas Aluminized
L	Heating Designation	Heat L - 210 MBtuh
2	Heating Staging	2 Stage

	Feature Option	Description
A	1A. RA/OA Section	Economizer
0	1B. RA/EA Blower Configuration	Standard - None
0	1C. RA/EA Blower	Standard - None
0	1D. RA/EA Blower Motor	Standard - None
C	2. OA Control	Fully Modulating Actuator - Sensible Limit
0	3. Heat Options	Standard
0	4. Maintenance Options	Standard
D	5A. SA Blower Configuration	1 Blower + Premium Efficiency Motor + 1 VFD
T	5B. SA Blower	17" Direct Drive Backward Curved Plenum
E	5C. SA Motor	3.0 hp - 1760 rpm
B	6A. Pre Filter Type	Metal Mesh OA Pre Filter
0	6B. Unit Filter Type	2" Pleated - 30% Eff
0	6C. Filter Options	Standard
0	7. Refrigeration Control	Standard - Adj Comp. Cooling Lock Out Through Unit Controls
0	8. Refrigeration Options	Standard
E	9. Refrigeration Accessories	ECM Condenser Fan - Head Pressure Control
B	10. Power Options	Non-fused Disconnect Power Switch - 150 Amps
0	11. Safety Options	Standard
0	12. Controls	Standard
E	13. Special Controls	Constant Volume (CV) Unit Controller - CV Cool + CV Heat
0	14A. Outside Air Configuration	Standard - None
0	14B. Preheat Sizing	Standard - None
0	15. Glycol Percent	Water or No WSHP
0	16. Interior Cabinet Options	Standard - Double Wall + R-13 Foam Insulation + Stainless Steel Drain Pan
C	17. Exterior Cabinet Options	Cond. Coil Guards
0	18. Customer Code	Standard
0	19. Code Options	Standard - ETL U.S.A. Listing
0	20. Crating	Standard
0	21. Water-Cooled Cond.	Standard - None
V	22. Control Vendors	VCC-X Controls + Integrated BACnet MSTP
B	23. Type	Standard - Includes AAON Gray Paint

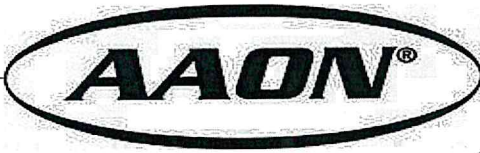

VCCX Components

2425 South Yukon Ave - Tulsa, Oklahoma 74107-2728 - Ph. (918) 583-2266 Fax (918) 583-6094
AAONEcat32 Ver. 4.292 (SN: 6303792-)

1A 1B 1C 1D 2 3 4 5A 5B 5C 6A 6B 6C 7 8 9 10 11 12 13 14A 14B 15 16 17 18 19 20 21 22 23

RN-008-8-0-KB09-2L2:A000-C00-DTE-B00-00EB00E-00-00C0000VB

Tag: RTU-4-VS

Job Name: *SAPULPA POLICE DEPARTMENT*

VCCX For:

Job Number: *SPD*

VCCX Date: *March 16, 2020*

Hardware Included For VCCX Controller

Part #	Included Parts	Assigned Channel	BACnet Point
ASM01698	VCCX2 CONTROLLER		
P94320	Space Temp Sensor	VCCX control point AI 1	AI:12
P94320	Space Temp Slide Adjust	VCCX control point AI 2	AI:8
R82890	Supply Temp Sensor - Field Installed	VCCX control point AI 3	AI:9
R81550	Outside Temp Sensor	VCCX control point AI 7	AI:16
	Supply Fan Control Signal 0-10VDC	VCCX control point AO 1	AI:22
	Economizer	VCCX control point AO 2	AI:30
R62330	Proof of Air Flow	VCCX control point BI 1	BI:6
	Safety Shut Down	VCCX control point BI 8	BI:26
	Supply Fan	Configured Relay point	BI:47
	Heat 1	Configured Relay Point	BI:48
	Heat 2	Configured Relay Point	BI:49



17.0" STAR Plenum

2425 South Yukon Ave - Tulsa, Oklahoma 74107-2728 - Ph. (918) 583-2266 Fax (918) 583-6094
AAONEcat32 Ver. 4.292 (SN: 6303792-)

JOB INFORMATION:

Job Name: *SAPULPA POLICE*
 Job Tag: *DEPARTMENT*
 Rep Firm: *RTU-4-VS*
 Date: *04/02/2020*

WHEEL SPECIFICATION:

Max RPM: *2,400*
 Diameter x Qty: *17.0 in. x 1*
 CFM: *17.0 in. x 1*
 Tip Speed: *3400*
 Inertia: *8,732 FPM*
3 WR²

OPERATING CONDITIONS:

Air Flow: *3,400 CFM*
 Static Pressure: *1.98 in. Wg.*
 Relief Dampers DP: *0.00 in. Wg.*
 TSP: *1.98 in. Wg.*
 Site Altitude: *715.00 Ft*
 TSP @ Sea Level: *2.03 in. Wg.*

MOTOR SELECTION:

Rated HP / Bypass: *3 / No*
 Frame Size: *182T*
 Nominal RPM: *1760*
 VAC/PH/HZ: *208/3/60*
 Efficiency: *Premium / 0.895*
 Enclosure Type: *ODP*
 Max Inertial Load: *29 WR²*

FAN PERFORMANCE:

RPM: *1962*
 BHP: *2.12*
 Efficiency: *50.1%*
 In/Out Velocity: *2313/2411 FPM*
 Plenum Out Velocity: *57 FPM*

FAN SOUND POWER (Inlet/Outlet):

Octave Band:	(Re 10 ⁻¹² watts)							
	1	2	3	4	5	6	7	8
	83	81	84	83	77	74	72	67
	83	81	84	83	77	74	72	67

SOUND POWER A-Weighted: 85 / 85 dB

Max Duct SP with Blocked Airway: *3.8 in. Wg. @ 1962 rpm*

Supply Fan Model: RN170 @ 1962 RPM and 100% Width
 Design Conditions: 3400 CFM @ 2.03" SP

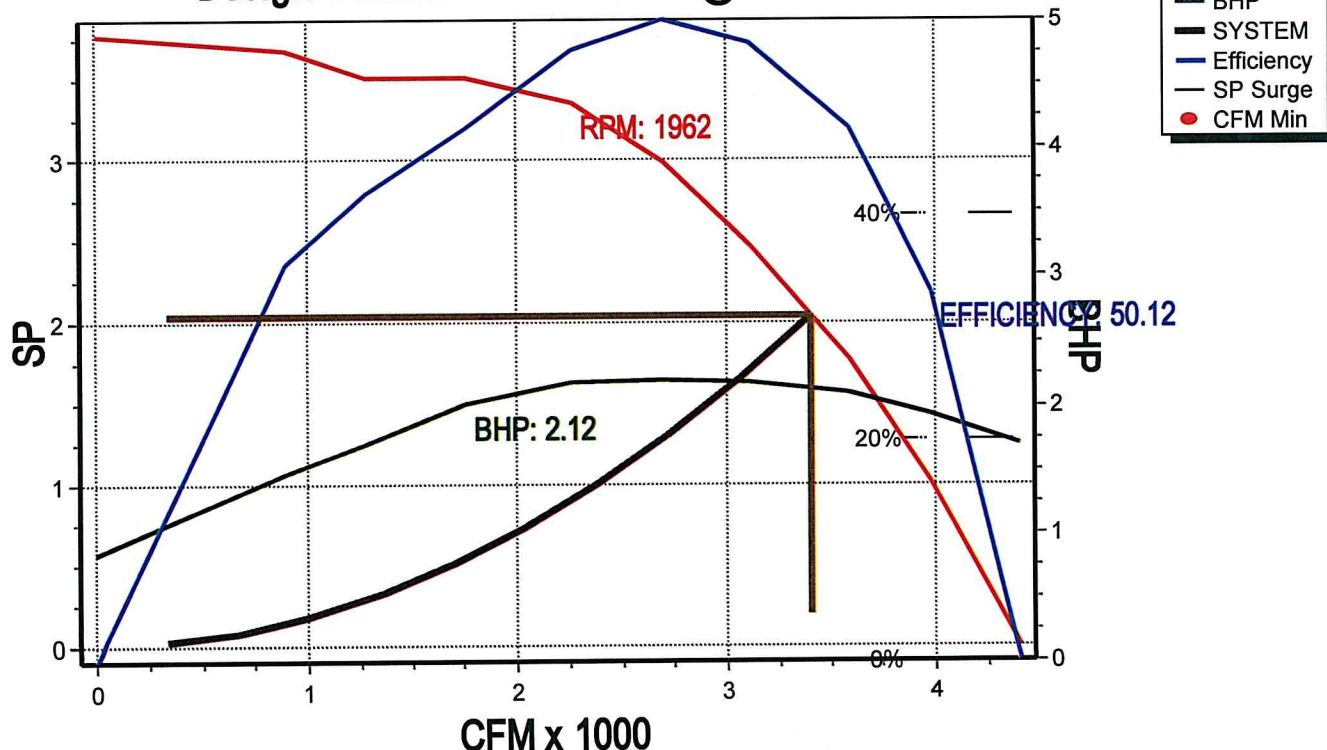

RN SERIES A - CABINET ECONOMIZER ~ 6-10 TON

CLEARANCES	
LOCATION	◦ UNIT SIZE ◦ 6 - 10 TON
OUTSIDE AIR (BACK)	36
CONTROLS SIDE (FRONT)	48
LEFT SIDE	6
RIGHT SIDE	48
TOP	UNOBSTRUCTED

NOTE: THE RNA UNIT IS NOT COMPATIBLE WITH PREVIOUS GENERATIONS OF AAO CURBS. AN ADAPTER CURB IS AVAILABLE IN ECAT.

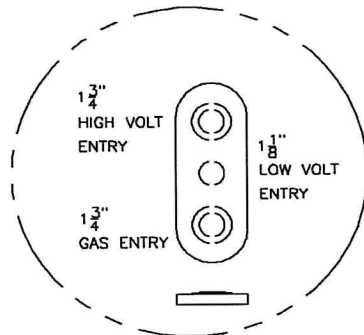

DETAIL A

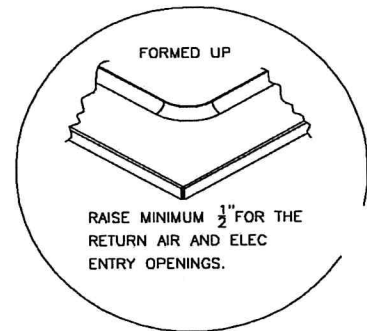

DETAIL B

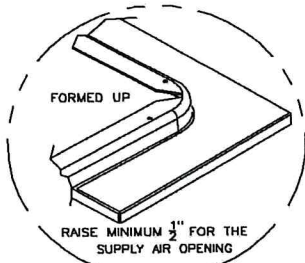

DETAIL C

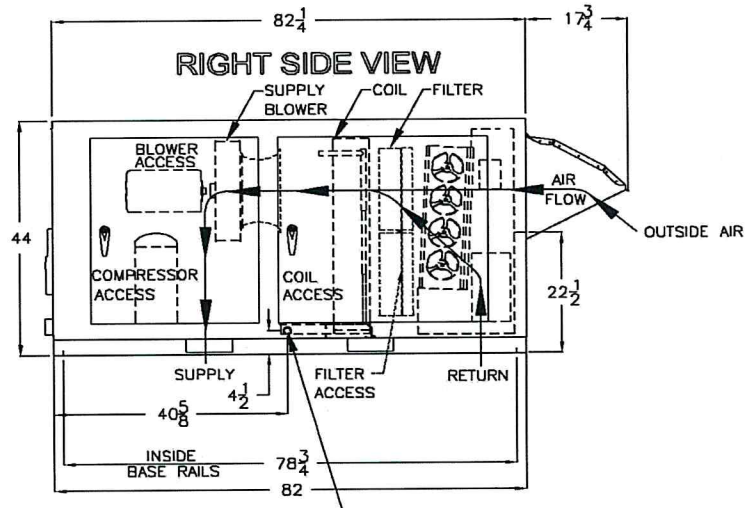
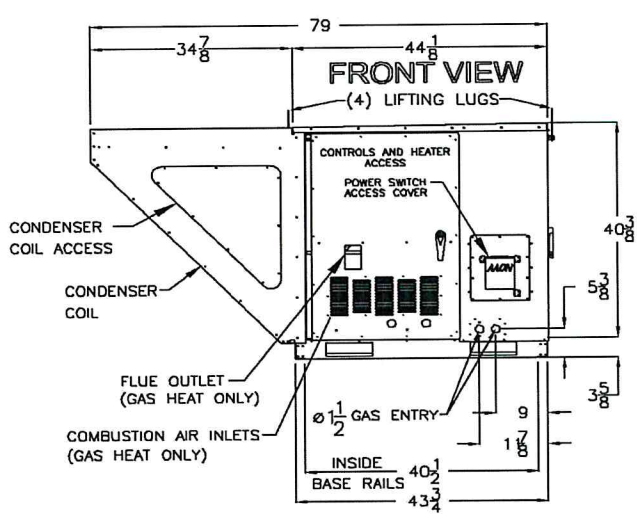
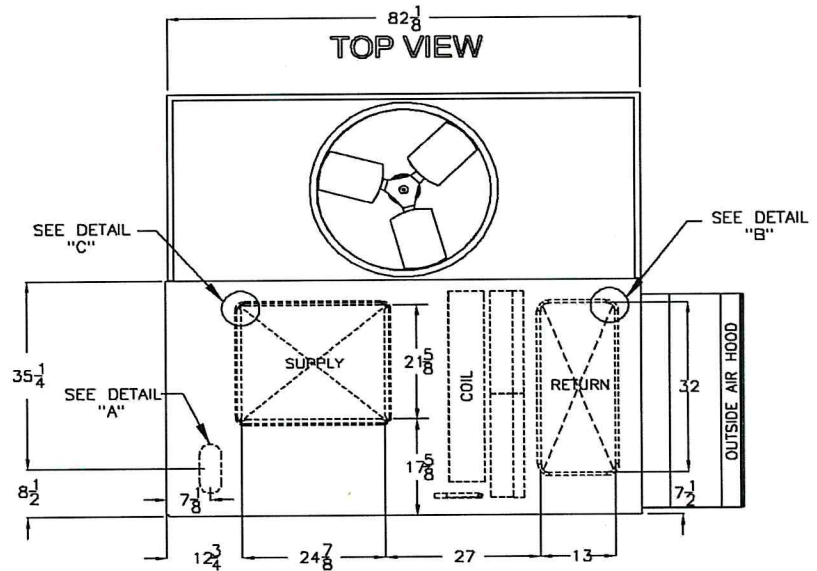

RNA-00013 NEW 09/15/09 JRL
NOTE: ALL DIMENSIONS ARE IN INCHES

RNA CABINET AIR COOLED CONDENSING UNIT



RN-008-8-0-KB09-2L2:A000-C00-DTE-B00-00EB00E-00-00C00000VB

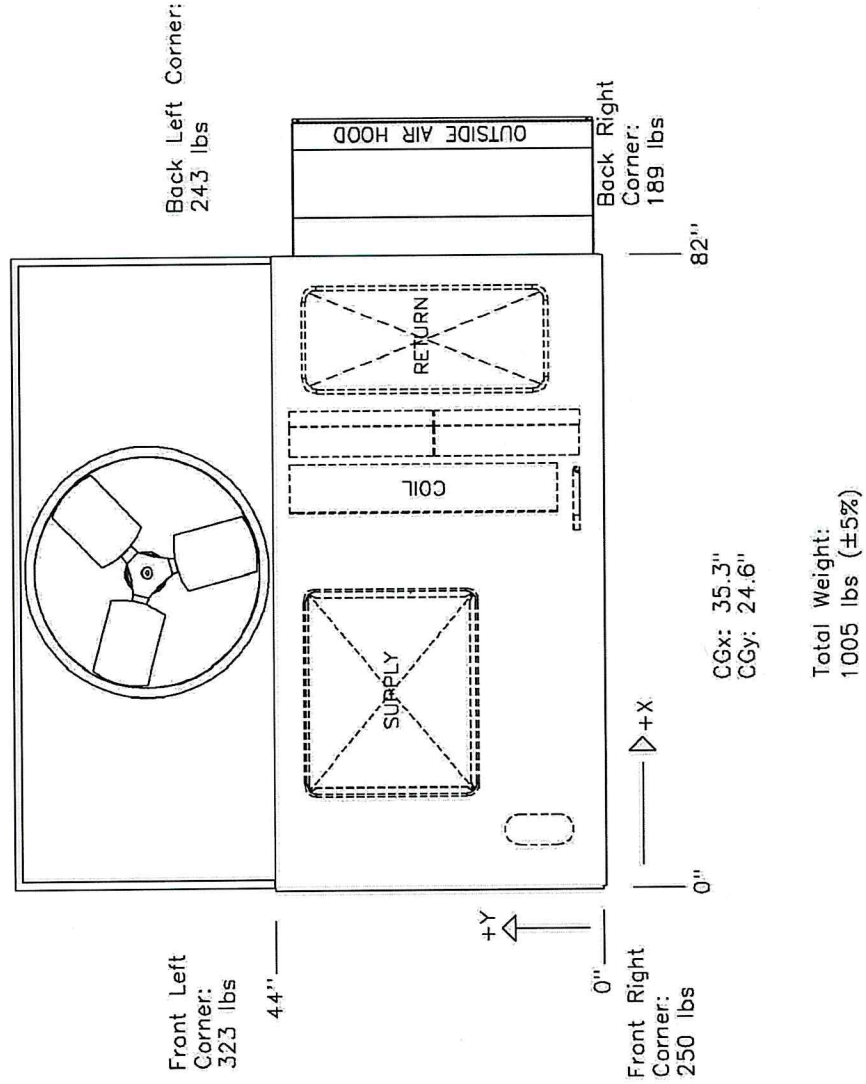

Disclaimer:
This weight estimate does not account for any SPAs.



Unit Rating

2425 South Yukon Ave - Tulsa, Oklahoma 74107-2728 - Ph. (918) 583-2266 Fax (918) 583-6094
AAONEcat32 Ver. 4.292 (SN: 6303792-)

1A 1B 1C 1D 2 3 4 5A 5B 5C 6A 6B 6C 7 8 9 10 11 12 13 14A 14B 15 16 17 18 19 20 21 22 23

RQ-005-8-V-KA09-251:A000-C00-QJD-B00-00EA002-00-0000000VB
Tag: RTU-5,9-VS

Job Information

Job Name: *SAPULPA POLICE DEPARTMENT*
 Job Number: *SPD*
 Site Altitude: *715 ft*
 Refrigerant: *R-410A*

Unit Information

Approx. Op./Ship Weights: *703 / 703 lbs. (±5%)*
 Supply CFM/ESP: *2000 / 0.55 in. wg.*
 Final Filter FV / Qty: *360.00 fpm / 2*
 Outside CFM: *600*
 Ambient Temperature: *100 °F DB / 78 °F WB*
 Return Temperature: *72 °F DB / 59 °F WB*

Static Pressure

External: *0.55 in. wg.*
 Evaporator: *0.33 in. wg.*
 Filters Clean: *0.15 in. wg.*
 Dirt Allowance: *0.35 in. wg.*

Economizer: *0.15 in. wg.*
 Heating: *0.12 in. wg.*
 Cabinet: *0.09 in. wg.*
 Total: *1.73 in. wg.*

Cooling Section

	Gross	Net
Total Capacity:	<i>57.10</i>	<i>53.89 MBH</i>
Sensible Capacity:	<i>49.08</i>	<i>45.87 MBH</i>
Latent Capacity:	<i>8.02 MBH</i>	
Mixed Air Temp:	<i>80.40 °F DB</i>	<i>65.57 °F WB</i>
Entering Air Temp:	<i>80.40 °F DB</i>	<i>65.57 °F WB</i>
Lv Air Temp (Coil):	<i>56.62 °F DB</i>	<i>55.87 °F WB</i>
Lv Air Temp (Unit):	<i>58.13 °F DB</i>	<i>56.45 °F WB</i>
Supply Air Fan:	<i>1 x RQ185-VFD @ 1.03 BHP</i>	
SA Fan RPM / Width:	<i>1549 / 3.000"</i>	
Evaporator Coil:	<i>5.3 ft² / 4 Rows / 14 FPI</i>	
Evaporator Face Velocity:	<i>381.0 fpm</i>	

Heating Section

PreHeat Type: *Std (No Preheat)*
 Heating Type: *Nat. Gas Heat*
 Heating CFM: *2000*
 Total Capacity: *113.4 MBH*
 OA Temp: *13.0 DB / 12.0 °F WB*
 RA Temp: *72.0 °F DB / 59.0 °F WB*
 Entering Air Temp: *54.3 °F DB / 48.2 °F WB*
 Leaving Air Temp: *106.8 °F DB / 67.9 °F WB*
 Input: *140.0 MBH*
 Heater Qty (Hi/Low): *1*
 Consumption: *140.0 MBH*
 Operation: *N/A*

Rating Information

Cooling Capacity (MBH): *62.0*
 Cooling SEER: *19*
 Cooling EER: *11.6*
Rated in accordance with AHRI 210/240

Application EER @ Op. Conditions: *9.1*

Electrical Data

Rating: *208/3/60*
 Unit FLA: *24*

Minimum Circuit Amp: *27*
 Maximum Overcurrent: *40*

	Qty	HP	VAC	Phase	RPM	FLA	RLA
Compressor 1:	1		208	3			13.5
Condenser Fans:	1	0.333	208	1	1110	2.8	
Supply Fan:	1	2.00	208	3	1760	7.5	
Combustion:	1	0.09	208	1	3000	1.3	

Cabinet Sound Power Levels*

Octave Bands:	63	125	250	500	1000	2000	4000	8000
Discharge LW(dB):	83	82	84	79	72	69	67	61
Return LW(dB):	79	78	74	67	63	61	57	48

*Sound power levels are given for informational purposes only. The sound levels are not guaranteed.

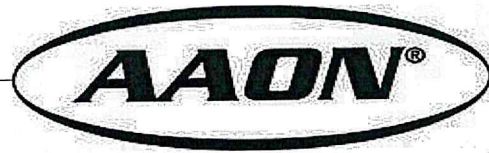

Unit Submittal

2425 South Yukon Ave - Tulsa, Oklahoma 74107-2728 - Ph. (918) 583-2266 Fax (918) 583-6094
AAONEcat32 Ver. 4.292 (SN: 6303792-)

1A 1B 1C 1D 2 3 4 5A 5B 5C 6A 6B 6C 7 8 9 10 11 12 13 14A 14B 15 16 17 18 19 20 21 22 23

RQ-005-8-V-KA09-251:A000-C00-QJD-B00-00EA002-00-0000000VB
Tag: RTU-5,9-VS

Job Name:
Job Number:

SAPULPA POLICE DEPARTMENT
SPD

Unit Submittal For:
Unit Submittal Date:

March 16, 2020

	Base Option	Description
R	Series	Roof Top Unit
Q	Generation	Tenth Generation
005	Unit Size	Five
8	Voltage	208V/3Ø/60Hz
V	Interior Protection	Vertical Discharge and Return
K	Refrigerant Style	R-410A Variable Speed Scroll Compressor - High Efficiency
A	Unit Configuration	Air-Cooled Cond. + Std Evap. Coil
0	Coil Coating	Standard
9	Cooling/Heat Pump Staging	1 Variable Speed Compressor
2	Heating Type	Natural Gas Aluminized
5	Heating Designation	Heat 5 - 140 MBtuh
1	Heating Staging	1 Stage

	Feature Option	Description
A	1A. RA/OA Section	Economizer
0	1B. RA/EA Blower Configuration	Standard - None
0	1C. RA/EA Blower	Standard - None
0	1D. RA/EA Blower Motor	Standard - None
C	2. OA Control	Fully Modulating Actuator - Sensible Limit
0	3. Heat Options	Standard
0	4. Maintenance Options	Standard
Q	5A. SA Blower Configuration	1 Blower + Inverter Rated 3 Phase Motor + VFD
J	5B. SA Blower	19" Direct Drive Backward Curved Plenum
D	5C. SA Motor	2 HP 1760 rpm
B	6A. Pre Filter Type	Metal Mesh OA Pre Filter
0	6B. Unit Filter Type	2" Pleated - MERV 8
0	6C. Filter Options	Standard
0	7. Refrigeration Control	Standard - Adj Comp. Cooling Lock Out Through Unit Controls
0	8. Refrigeration Options	Standard
E	9. Refrigeration Accessories	ECM Condenser Fan - Head Pressure Control
A	10. Power Options	Non-fused Disconnect Power Switch - 100 Amps
0	11. Safety Options	Standard
0	12. Controls	Standard
2	13. Special Controls	VAV Single Zone Unit Controller - VAV Cool + CAV Heat
0	14A. Preheat Configuration	Standard - None
0	14B. Preheat Sizing	Standard - None
0	15. Glycol Percent	Water or No WSHP
0	16. Interior Cabinet Options	Standard - Double Wall + R-13 Foam Insulation + Stainless Steel Drain Pan
0	17. Exterior Cabinet Options	Standard
0	18. Customer Code	Standard
0	19. Code Options	Standard - ETL U.S.A. Listing
0	20. Crating	Standard
0	21. Water-Cooled Cond.	Standard - None
V	22. Control Vendors	VCCX w/ BACnet MSTP
B	23. Type	Standard - Includes AAON Gray Paint



VCCX Components

2425 South Yukon Ave - Tulsa, Oklahoma 74107-2728 - Ph. (918) 583-2266 Fax (918) 583-6094
AAONEcat32 Ver. 4.292 (SN: 6303792-)

1A 1B 1C 1D 2 3 4 5A 5B 5C 6A 6B 6C 7 8 9 10 11 12 13 14A 14B 15 16 17 18 19 20 21 22 23

RQ-005-8-V-KA09-251:A000-C00-QJD-B00-00EA002-00-0000000VB

Tag: RTU-5,9-VS

Job Name: **SAPULPA POLICE DEPARTMENT**

VCCX For:

Job Number: **SPD**

VCCX Date: **March 16, 2020**

Hardware Included For VCCX Controller

Part #	Included Parts	Assigned Channel	BACnet Point
ASM01698	VCCX2 CONTROLLER		
P94320	Space Temp Sensor	VCCX control point AI 1	AI:12
P94320	Space Temp Slide Adjust	VCCX control point AI 2	AI:8
R82890	Supply Temp Sensor - Field Installed	VCCX control point AI 3	AI:9
R81550	Outside Temp Sensor	VCCX control point AI 7	AI:16
	Supply Fan Control Signal 0-10VDC	VCCX control point AO 1	AI:22
	Economizer	VCCX control point AO 2	AI:30
R62330	Proof of Air Flow	VCCX control point BI 1	BI:6
	Safety Shut Down	VCCX control point BI 8	BI:26
	Supply Fan	Configured Relay point	BI:47
	Heat 1	Configured Relay Point	BI:48
ASM01686	REFRIGERATION MODULE		
V38391	Suction Pressure Sensor	RSMV 1 point AI 1	AI:48
V38410	Discharge Pressure Sensor	RSMV 1 point AI 2	AI:50
	Modulated Condenser Signal	RSMV 1 point AO2	AI:46
	Comp Status Input 1	RSMV 1 point BI 1	BI:79
	Comp Enable 1	RSMV 1 Fixed Relay point	BI:77,BI:84



18.5" STAR Plenum

2425 South Yukon Ave - Tulsa, Oklahoma 74107-2728 - Ph. (918) 583-2266 Fax (918) 583-6094
AAONEcat32 Ver. 4.292 (SN: 6303792)

JOB INFORMATION:

Job Name: SAPULPA POLICE
Job Tag: DEPARTMENT
Rep Firm: RTU-5,9-VS
Date: 04/02/2020
04/02/2020

WHEEL SPECIFICATION:

Max RPM: 2,200
Diameter x Qty: 18.5 in. x 1
CFM: 2000
Tip Speed: 7,502 FPM
Inertia: 7,502 FPM

OPERATING CONDITIONS:

Air Flow: 2,000 CFM
Static Pressure: 1.73 in. Wg.
Relief Dampers DP: 0.00 in. Wg.

TSP: 1.73 in. Wg.
Site Altitude: 715.00 Ft
TSP @ Sea Level: 1.78 in. Wg.

MOTOR SELECTION:

Rated HP / Bypass: 2 / No
Frame Size: 48
Nominal RPM: 1760
VAC/PH/Hz: 208/3/60
Efficiency: Standard / 0.815
Enclosure Type: ODP
Max Inertial Load: 27 WR²

FAN PERFORMANCE:

RPM: 1549
BHP: 1.03
Efficiency: 53.1%
In/Out Velocity: / FPM
Plenum Out Velocity: 33 FPM

FAN SOUND POWER (Inlet/Outlet):

Octave Band:	(Re 10 ⁻¹² watts)							
	1	2	3	4	5	6	7	8
	83	82	84	81	75	73	71	65
	83	82	84	81	75	73	71	65

SOUND POWER A-Weighted: 84 / 84 dB

Max Duct SP with Blocked Airway: 2.6 in. Wg. @ 1549 rpm

Supply Fan Model: RQ185-VFD @ 1549 RPM and 100% Width
Design Conditions: 2000 CFM @ 1.78" SP

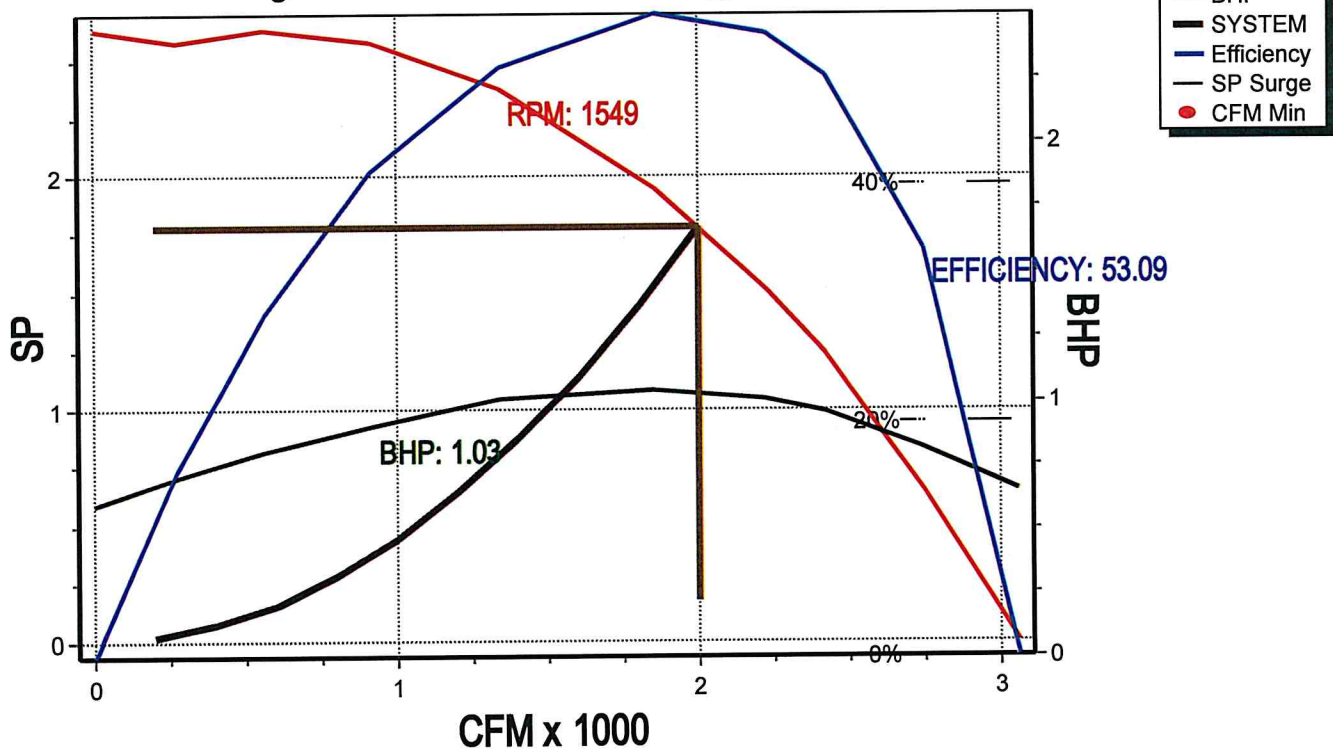

RQ CABINET ECONOMIZER VERTICAL ~ 1-6 TON

CLEARANCES	
LOCATION	• UNIT SIZE • 1 - 6 TON
OUTSIDE AIR (BACK)	36*
HXC (FRONT)	36
LEFT SIDE	24
RIGHT SIDE	48
TOP	UNOBSTRUCTED

***CLEARANCE IS MEASURED FROM THE END OF THE OUTSIDE AIR RAIN HOOD**

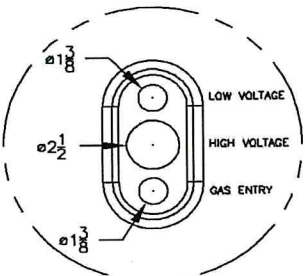

DETAIL A

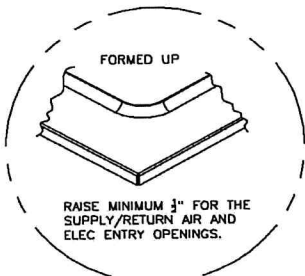

DETAIL B

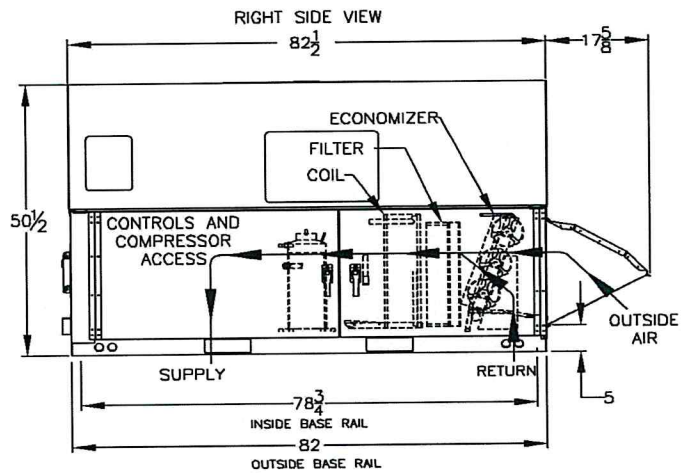
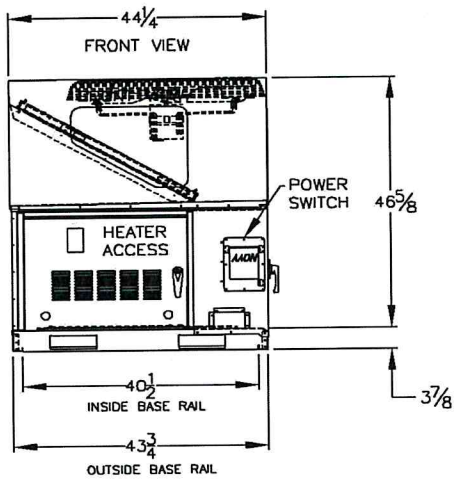
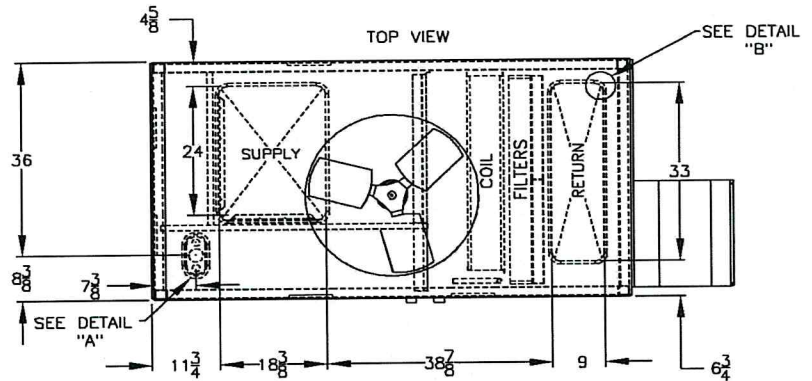
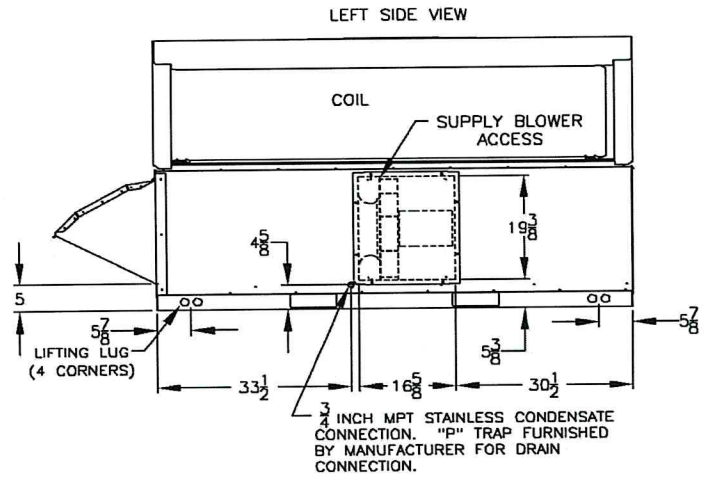



RQ CABINET VERTICAL AIR COOLED CONDENSING UNIT

RQ-005-8-V-KA09-251:A000-C00-QJD-B00-00EA002-00-00000000VB

Back Left Corner:
157 lbs

Front Left
Corner:
183 lbs

44"

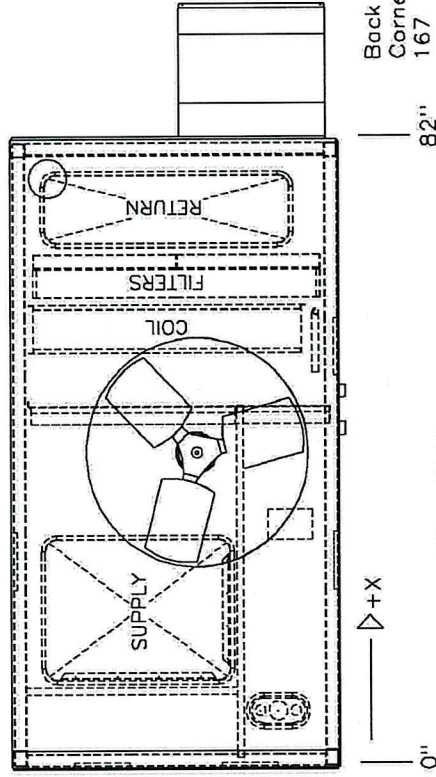

Back Right
Corner:
167 lbs

Front Right
Corner:
195 lbs

82"

CGx: 37.9"
CGy: 21.2"

Total Weight:
703 lbs (±5%)

Disclaimer:
This weight estimate does not account for any SPAs.

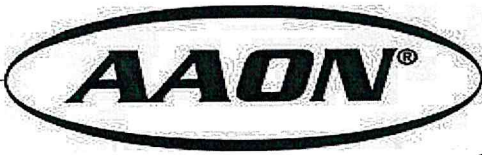

Unit Rating

2425 South Yukon Ave - Tulsa, Oklahoma 74107-2728 - Ph. (918) 583-2266 Fax (918) 583-6094
AAONEcat32 Ver. 4.292 (SN: 6303792-)

1A 1B 1C 1D 2 3 4 5A 5B 5C 6A 6B 6C 7 8 9 10 11 12 13 14A 14B 15 16 17 18 19 20 21 22 23

RN-010-8-0-KB09-3K9 : K000-000-DGC-B00-0DEA00F-00-0JC0000VB
Tag: MUA-1-VS

Job Information

Job Name: *SAPULPA POLICE DEPARTMENT*
Job Number: *SPD*
Site Altitude: *715 ft*
Refrigerant: *R-410A*

Unit Information

Approx. Op./Ship Weights: *965 / 965 lbs. (±5%)*
Supply CFM/ESP: *1300 / 0.5 in. wg.*
Final Filter FV / Qty: *146.25 fpm / 4*
Outside CFM: *1300*
Ambient Temperature: *105 °F DB / 78 °F WB*

Static Pressure

External: *0.50 in. wg.*
Evaporator: *0.14 in. wg.*
Filters Clean: *0.06 in. wg.*
Dirt Allowance: *0.35 in. wg.*

Economizer: *0.00 in. wg.*
Heating: *0.02 in. wg.*
Cabinet: *0.02 in. wg.*
Re-Heat Coil: *0.01 in. wg.*
Total: *1.11 in. wg.*

Cooling Section

	Gross	Net
Total Capacity:	<i>105.27</i>	<i>104.01 MBH</i>
Sensible Capacity:	<i>67.81</i>	<i>66.54 MBH</i>
Latent Capacity:	<i>37.46 MBH</i>	
Mixed Air Temp:	<i>105.00 °F DB</i>	<i>78.00 °F WB</i>
Entering Air Temp:	<i>105.00 °F DB</i>	<i>78.00 °F WB</i>
Lv Air Temp (Coil):	<i>51.93 °F DB</i>	<i>51.88 °F WB</i>
Lv Air Temp (Unit):	<i>52.85 °F DB</i>	<i>52.26 °F WB</i>
Supply Air Fan:	<i>1 x RN150D70 @ 0.43 BHP</i>	
SA Fan RPM / Width:	<i>1543 / 2.352"</i>	
Evaporator Coil:	<i>8.5 ft² / 6 Rows / 14 FPI</i>	
Evaporator Face Velocity:	<i>152.8 fpm</i>	

Heating Section

PreHeat Type: *Std (No Preheat)*
Heating Type: *Nat. Gas Heat*
Heating CFM: *1300*
Total Capacity: *120.0 MBH*
OA Temp: *10.0 °F DB / 9.0 °F WB*
RA Temp: *75.0 °F DB / 62.0 °F WB*
Entering Air Temp: *10.0 °F DB / 9.0 °F WB*
Leaving Air Temp: *95.4 °F DB / 56.6 °F WB*
Input: *150.0 MBH*
Heater Qty: *1*
Consumption: *150.0 MBH*
Total Turndown Ratio: *3:1*

Re-Heat Coil:

Capacity: *25 MBH*
LA DB / WB: *70.00 °F / 58.97 °F*
RH: *52%*

Rating Information

Cooling Capacity (MBH): *117.0*
Cooling EER: *11.1*
Cooling IEER: *21.5*
Rated in accordance with AHRI 340/360

Application EER @ Op. Conditions: 9.9

Electrical Data

Rating: *208/3/60*
Unit FLA: *39*

Minimum Circuit Amp: *46*
Maximum Overcurrent: *70*

	Qty	HP	VAC	Phase	RPM	FLA	RLA
Compressor 1:	1		208	3			27.2
Condenser Fans:	1	1.00	208	1	1110	7.0	
Supply Fan:	1	1.00	208	3	1760	4.6	
Combustion:	1	0.09	208	1	3010	1.3	

Cabinet Sound Power Levels*

Octave Bands:	63	125	250	500	1000	2000	4000	8000
Discharge LW(dB):	75	73	76	72	65	63	59	52
Return LW(dB):	65	65	62	54	50	47	41	29

*Sound power levels are given for informational purposes only. The sound levels are not guaranteed.



Unit Submittal

2425 South Yukon Ave - Tulsa, Oklahoma 74107-2728 - Ph. (918) 583-2266 Fax (918) 583-6094
AAONEcat32 Ver. 4.292 (SN: 6303792-)

1A 1B 1C 1D 2 3 4 5A 5B 5C 6A 6B 6C 7 8 9 10 11 12 13 14A 14B 15 16 17 18 19 20 21 22 23

RN-010-8-0-KB09-3K9 : K000-000-DGC-B00-0DEA00F-00-0JC0000VB
Tag: MUA-1-VS

Job Name:
Job Number:

SAPULPA POLICE DEPARTMENT
SPD

Unit Submittal For:
Unit Submittal Date:

March 16, 2020

	Base Option	Description
R	Series	Roof Top Unit
N	Generation	Ninth Generation
010	Unit Size	Ten
8	Voltage	208V/3Ø/60Hz
0	Interior Protection	Standard
K	Refrigerant Style	R-410A Variable Speed Scroll Compressor - High Efficiency
B	Unit Configuration	Air-Cooled Cond. + 6 Row Evap. Coil
0	Coil Coating	Standard
9	Cooling/Heat Pump Staging	Modulating - 1 Variable Capacity Compressor
3	Heating Type	Natural Gas Stainless Steel
K	Heating Designation	Heat K - 150 MBtuh
9	Heating Staging	Modulating Gas - Temperature Control

	Feature Option	Description
K	1A. RA/OA Section	100% Outside Air - No RA Opening
0	1B. RA/EA Blower Configuration	Standard - None
0	1C. RA/EA Blower	Standard - None
0	1D. RA/EA Blower Motor	Standard - None
0	2. OA Control	Standard - None
0	3. Heat Options	Standard
0	4. Maintenance Options	Standard
D	5A. SA Blower Configuration	1 Blower + Premium Efficiency Motor + 1 VFD
G	5B. SA Blower	15" Direct Drive Backward Curved Plenum - 70% Width
C	5C. SA Motor	1.0 hp - 1760 rpm
B	6A. Pre Filter Type	Metal Mesh OA Pre Filter
0	6B. Unit Filter Type	2" Pleated - 30% Eff
0	6C. Filter Options	Standard
0	7. Refrigeration Control	Standard - Adj Comp. Cooling Lock Out Through Unit Controls
D	8. Refrigeration Options	Modulating Hot Gas Reheat
E	9. Refrigeration Accessories	ECM Condenser Fan - Head Pressure Control
A	10. Power Options	Non-fused Disconnect Power Switch - 100 Amps
0	11. Safety Options	Standard
0	12. Controls	Standard
F	13. Special Controls	Make Up Air Unit Controller - CV Cool + CV Heat
0	14A. Outside Air Configuration	Standard - None
0	14B. Preheat Sizing	Standard - None
0	15. Glycol Percent	Water or No WSHP
J	16. Interior Cabinet Options	Compressor Sound Blankets
C	17. Exterior Cabinet Options	Cond. Coil Guards
0	18. Customer Code	Standard
0	19. Code Options	Standard - ETL U.S.A. Listing
0	20. Crating	Standard
0	21. Water-Cooled Cond.	Standard - None
V	22. Control Vendors	VCC-X Controls + Integrated BACnet MSTP
B	23. Type	Standard - Includes AAON Gray Paint



VCCX Components

2425 South Yukon Ave - Tulsa, Oklahoma 74107-2728 - Ph. (918) 583-2266 Fax (918) 583-6094
AAONEcat32 Ver. 4.292 (SN: 6303792)

1A 1B 1C 1D 2 3 4 5A 5B 5C 6A 6B 6C 7 8 9 10 11 12 13 14A 14B 15 16 17 18 19 20 21 22 23

RN-010-8-0-KB09-3K9:K000-000-DGC-B00-0DEA00F-00-0JC0000VB

Tag: MUA-1-VS

Job Name: **SAPULPA POLICE
DEPARTMENT**

VCCX For:

Job Number: **SPD**

VCCX Date:

March 16, 2020

Hardware Included For VCCX Controller

Part #	Included Parts	Assigned Channel	BACnet Point
ASM01698	VCCX2 CONTROLLER		
V13050	OSA Temp/Hum Sensor	EBUS2 communicating sensor	AI:16,AI:17,AI:18,AI:19
R82890	Supply Temp Sensor - Field Installed	VCCX control point AI 3	AI:9
	Supply Fan Control Signal 0-10VDC	VCCX control point AO 1	AI:22
R62330	Proof of Air Flow	VCCX control point BI 1	BI:6
	Safety Shut Down	VCCX control point BI 8	BI:26
	Supply Fan	Configured Relay point	BI:47
ASM02201	DIGITAL REFRIGERATION MODULE		
V38391	Suction Pressure Sensor A	RSMD point SP-1	AI:48
ASM01670	MODULATING HOT GAS REHEAT MODULE		
	Reheat HGR Valve	MHGRV-X	AI:42
ASM01695	MODULATING GAS MODULE		
	ModGas Proof of Ignition 1	MODGAS-XWR	
	ModGas Low Speed Enable	MODGAS-XWR	
	ModGas Heat 1 Enable	MODGAS-XWR	



15.0" STAR Plenum

2425 South Yukon Ave - Tulsa, Oklahoma 74107-2728 - Ph. (918) 583-2266 Fax (918) 583-6094
AAONEcat32 Ver. 4.292 (SN: 6303792-)

JOB INFORMATION:

Job Name: *SAPULPA POLICE*
 Job Tag: *DEPARTMENT*
 Rep Firm: *MUA-1-VS*
 Date: *04/02/2020*
04/02/2020

WHEEL SPECIFICATION:

Max RPM: *2,600*
 Diameter x Qty: *15.0 in. x 1*
 CFM: *1300*
 Tip Speed: *1300*
 Inertia: *6,059 FPM*
6,059 FPM

OPERATING CONDITIONS:

Air Flow: *1,300 CFM*
 Static Pressure: *1.11 in. Wg.*
 Relief Dampers DP: *0.00 in. Wg.*
 TSP: *1.11 in. Wg.*
 Site Altitude: *715.00 Ft*
 TSP @ Sea Level: *1.14 in. Wg.*

MOTOR SELECTION:

Rated HP / Bypass: *1 / No*
 Frame Size: *143T*
 Nominal RPM: *1760*
 VAC/PH/HZ: *208/3/60*
 Efficiency: *Premium / 0.855*
 Enclosure Type: *ODP*
 Max Inertial Load: *15 WR²*

FAN PERFORMANCE:

RPM: *1543*
 BHP: *0.43*
 Efficiency: *53.4%*
 In/Out Velocity: */ FPM*
 Plenum Out Velocity: *22 FPM*

FAN SOUND POWER (Inlet/Outlet):

Octave Band:	(Re 10 ⁻¹² watts)							
	1	2	3	4	5	6	7	8
	75	73	76	73	68	66	63	56
	75	73	76	73	68	66	63	56

SOUND POWER A-Weighted: *77 / 77 dB*

Max Duct SP with Blocked Airway: *1.8 in. Wg. @ 1543 rpm*

Supply Fan Model: RN150D70 @ 1543 RPM and 100% Width
 Design Conditions: 1300 CFM @ 1.14" SP

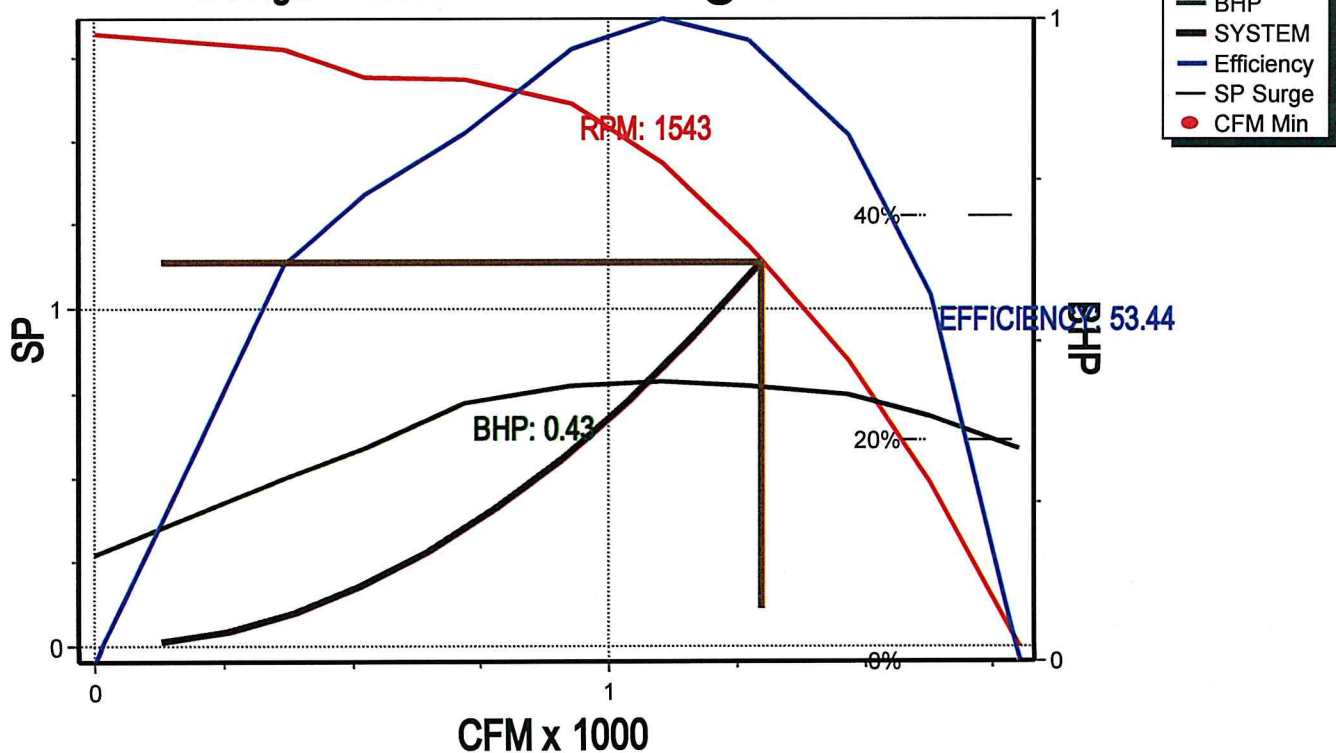

RN SERIES A - CABINET STANDARD ~ 6-10 TON

CLEARANCES	
LOCATION	• UNIT SIZE • 6 - 10 TON
OUTSIDE AIR (BACK)	36
CONTROLS SIDE (FRONT)	48
LEFT SIDE	6
RIGHT SIDE	48
TOP	UNOBSTRUCTED

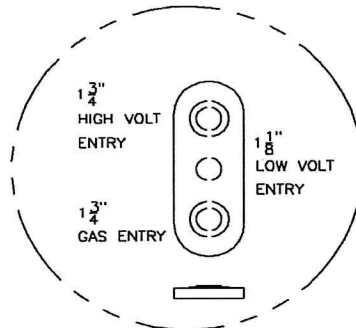

DETAIL A

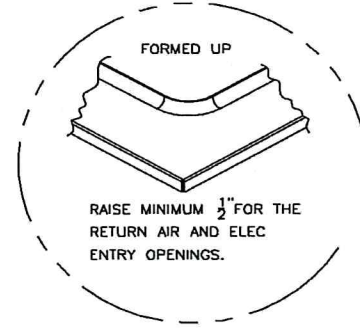

DETAIL B

NOTE: THE RNA UNIT IS NOT COMPATIBLE WITH PREVIOUS GENERATIONS OF AAON CURBS. AN ADAPTER CURB IS AVAILABLE IN ECAT.

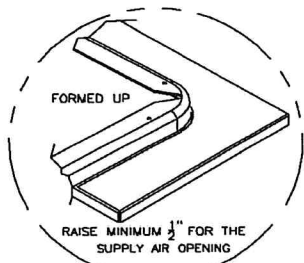

DETAIL C

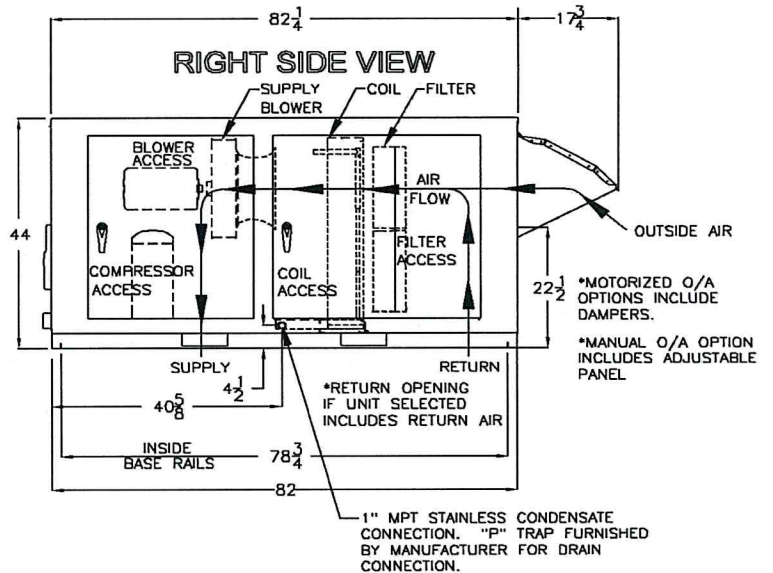
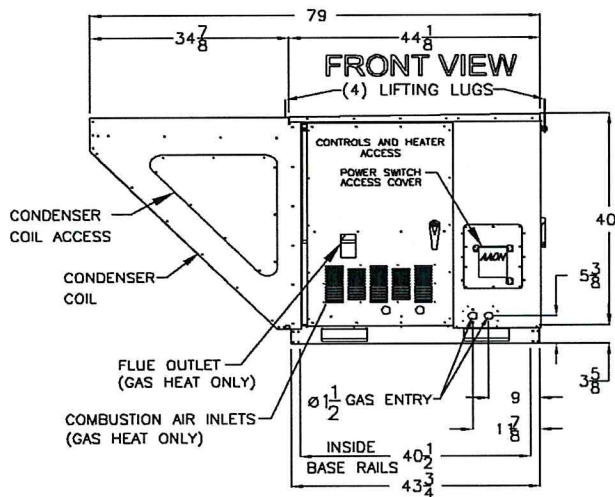
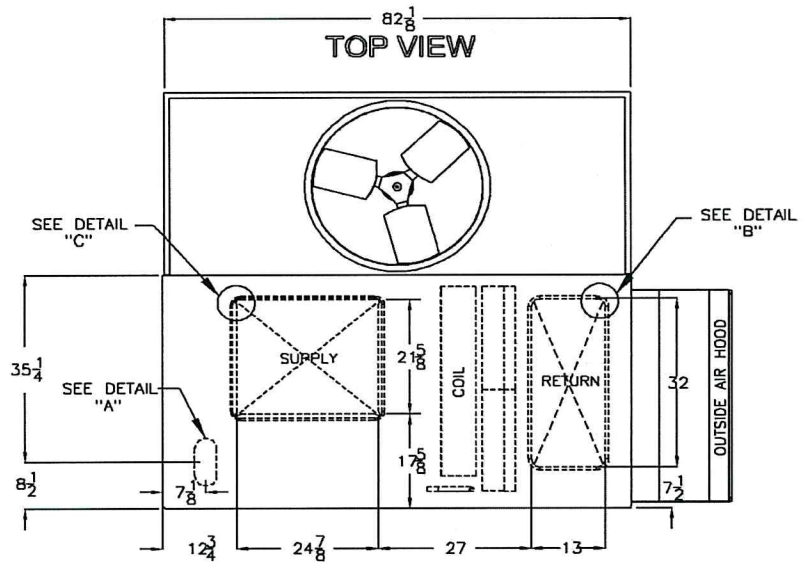

RNA CABINET AIR COOLED CONDENSING UNIT



RN-010-8-0-KB09-3K9:K000-000-DGC-B00-0DEA00F-00-0JC00000VB

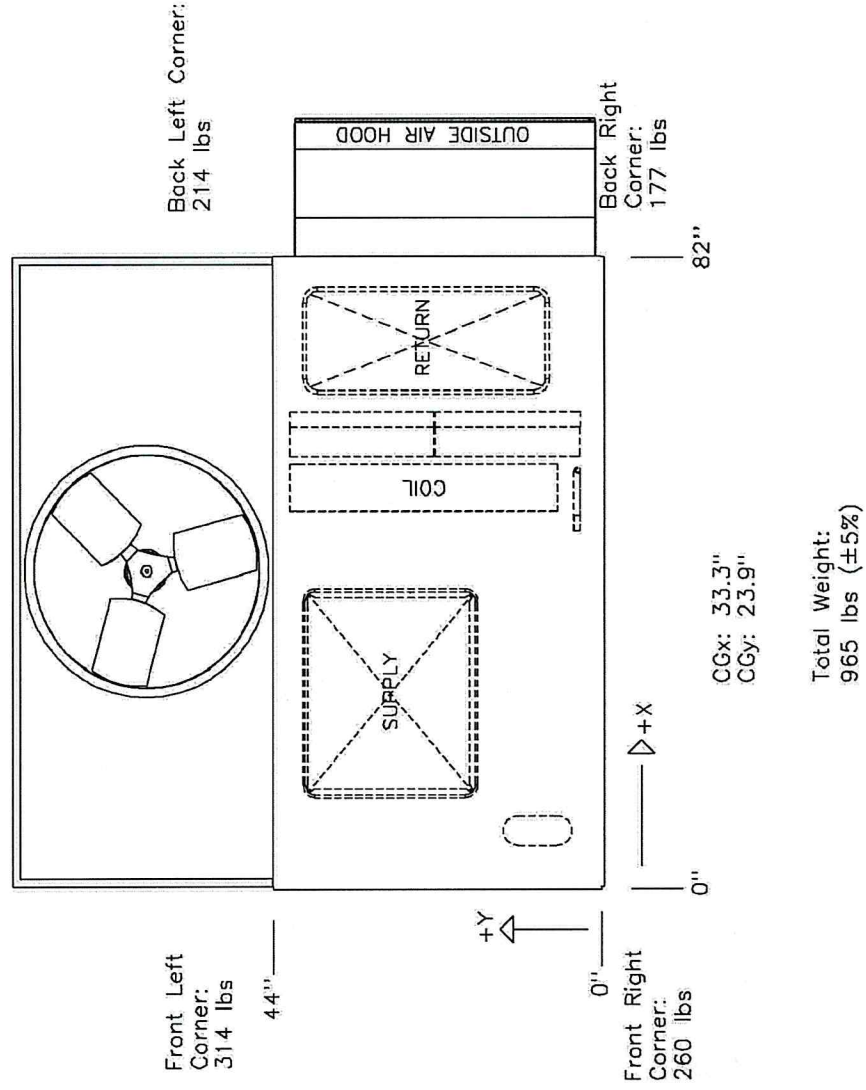

Disclaimer:
This weight estimate does not account for any SPAs.



AGENDA ITEM

Administration 11. F.

City Council Regular

Meeting Date: April 20, 2020

Submitted For: David Widdoes, City Attorney

Submitted By: Amy Hoehner, Legal Assistant

Department: Legal

Presented By: David Widdoes

SUBJECT:

Discussion and possible action regarding Agreement for Professional Services with Olsson, Inc. dba Oschner Hare & Hare the Olsson Studio ("Olsson") for creation of a Downtown Sapulpa Master Plan in the amount of \$197,000.00.

BACKGROUND:

A request for proposal (RFP) for the creation of a Downtown Master Plan was sent out to all qualified firms who responded to the City's request for qualifications. The purpose of the RFP was to identify a consultant that could supply the City of Sapulpa with a long term, visionary, and comprehensive Downtown Master Plan with the goal of attracting quality and sustainable growth and economic development.

On February 17, 2020, the RFP's were presented to the City Council by the following firms: (i) RDG/PDG, (ii) McClelland Consulting Engineers, Inc, (iii) BKL, Inc., and (iv) Oschner Hare & Hare the Olsson Studio. On March 9, 2020, the Administration and Finance Committee met and recommended that the City Council retain Oschner Hare & Hare, the Olsson Studio ("Olsson") to provide the required services to create the City's Downtown Master Plan.

The attached Agreement for Professional Services has been reviewed and provides for completion of all services, as represented by Olsson at the presentation, including kickoff, management and progress meetings, branding, comprehensive mapping and data analysis, economic and market positioning analysis and strategy, transportation and parking analysis, online, in-person and community engagement, culminating in a refined downtown master plan for the community. These services shall commence with an estimated start date of May 2020 and are estimated to be completed in April 2021. The costs of these services shall not exceed \$197,000.00, and is payable 30 days after receipt upon an approved invoice detailing services rendered. The funds necessary for these services are available from the bond sale proceeds authorized by City Council

Resolution 4620.

RECOMMENDATION:

Staff recommends that the City Council approve the referenced agreement as stated.

Fiscal Impact

Amount: \$197,000.00

To be paid from: GO Bond Construction Fund

Account number: 83-580-311

Attachments

Agreement

LETTER AGREEMENT FOR PROFESSIONAL SERVICES

March 10, 2020

City of Sapulpa, Oklahoma
Attn: Nikki Howard
424 E Hobson Ave
Sapulpa, OK 74066

Re: **LETTER AGREEMENT FOR PROFESSIONAL SERVICES**
Downtown Sapulpa Master Plan (the "Project")
Sapulpa, Oklahoma

Dear Ms. Howard:

It is our understanding that the City of Sapulpa, Oklahoma ("Client") requests Olsson, Inc. dba Ochsner Hare & Hare the Olsson Studio ("Olsson") to perform the services described herein pursuant to the terms of this Letter Agreement for Professional Services, Olsson's General Provisions and any exhibits attached hereto (all documents constitute and are referred to herein as the "Agreement") for the Project.

Olsson has acquainted itself with the information provided by Client relative to the Project and based upon such information offers to provide the services described below for the Project. Client warrants that it is either the legal owner of the property to be improved by this Project or that Client is acting as the duly authorized agent of the legal owner of such property. Client acknowledges that it has reviewed the General Provisions and any exhibits attached hereto, which are expressly made a part of and incorporated into the Agreement by this reference. In the event of any conflict or inconsistency between this Letter Agreement, and the General Provisions regarding the services to be performed by Olsson, the terms of the General Provisions shall take precedence.

Olsson shall provide the following services ("Scope of Services") to Client for the Project as more specifically described in "Scope of Services" attached hereto. Should Client request work in addition to the Scope of Services, Olsson shall invoice Client for such additional services (Optional Additional Services) at the standard hourly billing labor rate charged for those employees actually performing the work, plus reimbursable expenses if any. Olsson shall not commence work on Optional Additional Services without Client's prior written approval.

Olsson agrees to provide all of its services in a timely, competent and professional manner, in accordance with applicable standards of care, for projects of similar geographic location, quality and scope.

SCHEDULE FOR OLSSON'S SERVICES

Unless otherwise agreed, Olsson expects to perform its services under the Agreement as follows:

Anticipated Start Date: May 2020
Anticipated Completion Date: April 2021

Olsson will endeavor to start its services on the Anticipated Start Date and to complete its services on the Anticipated Completion Date. However, the Anticipated Start Date, the Anticipated Completion Date, and any milestone dates are approximate only, and Olsson reserves the right to adjust its schedule and any or all of those dates at its sole discretion, for any reason, including, but not limited to, delays caused by Client or delays caused by third parties.

COMPENSATION

Client shall pay to Olsson for the performance of the Scope of Services a lump sum of One Hundred Ninety-Seven Thousand Dollars (\$197,000.00). Olsson's reimbursable expenses for this project are included in the lump sum. Olsson shall submit invoices on a monthly basis, and payment is due within 30 calendar days of invoice date.

TERMS AND CONDITIONS OF SERVICE

We have discussed with you the risks, rewards and benefits of the Project, the Scope of Services, and our fees for such services and the Agreement represents the entire understanding between Client and Olsson with respect to the Project. The Agreement may only be modified in writing signed by both parties.

Client's designated Project Representative shall be _____.

If this Agreement satisfactorily sets forth your understanding of our agreement, please sign in the space provided below. Retain one original for your files and return an executed original to Olsson. This proposal will be open for acceptance for a period of 30 days from the date set forth above, unless changed by us in writing.

OLSSON, INC. DBA OCHSNER HARE & HARE THE OLSSON STUDIO

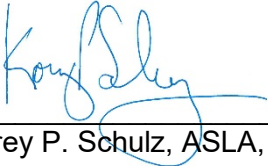
By  _____
Korey P. Schulz, ASLA, PLA

By  _____
Ken Boone, Vice President

By signing below, you acknowledge that you have full authority to bind Client to the terms of the Agreement. If you accept the terms set forth herein, please sign:

CITY OF SAPULPA, OKLAHOMA

By _____
Signature

Print Name _____

Title _____

Dated _____

- Attachments
General Provisions
Scope of Services

GENERAL PROVISIONS

These General Provisions are attached to and made a part of the respective Letter Agreement or Master Agreement, dated March 10, 2020 between City of Sapulpa, Oklahoma ("Client") and Olsson, Inc. ("Olsson") for professional services in connection with the project or projects arising under such Letter Agreement or Master Agreement (the "Project(s)").

As used herein, the term "this Agreement" refers to these General Provisions, the applicable Letter Agreement or Master Agreement, and any other exhibits or attachments thereto as if they were part of one and the same document.

SECTION 1—OLSSON'S SCOPE OF SERVICES

Olsson's scope of services for the Project(s) is set forth in the applicable Letter Agreement or Master Agreement ("Scope of Services").

SECTION 2—ADDITIONAL SERVICES

2.1 Unless otherwise expressly included, Scope of Services does not include the categories of additional services set forth in Sections 2.2 and 2.3.

2.2 If Client and Olsson mutually agree for Olsson to perform any optional additional services as set forth in this Section 2.2 ("Optional Additional Services"), Client will provide written approval of the agreed-upon Optional Additional Services, and Olsson shall perform or obtain from others such services and will be entitled to an increase in compensation at rates provided in this Agreement. Olsson may elect not to perform all or any of the Optional Additional Services without cause or explanation:

2.2.1 Preparation of applications and supporting documents for governmental financial support of the Project(s); preparation or review of environmental studies and related services; and assistance in obtaining environmental approvals.

2.2.2 Services to make measured drawings of or to investigate existing conditions of facilities.

2.2.3 Services resulting from changes in the general scope, extent or character of the Project(s) or major changes in documentation previously accepted by Client where changes are due to causes beyond Olsson's control.

2.2.4 Services resulting from the discovery of conditions or circumstances which were not contemplated by Olsson at the commencement of this Agreement. Olsson shall notify Client of the newly discovered conditions or circumstances and Client and Olsson shall renegotiate, in good faith, the compensation for this Agreement, if amended terms cannot be agreed upon, Olsson may terminate this Agreement and Olsson shall be paid for its services through the date of termination.

2.2.5 Providing renderings or models.

2.2.6 Preparing documents for alternate bids requested by Client.

2.2.7 Analysis of operations, maintenance or overhead expenses; value engineering; the preparation of rate

schedules; earnings or expense statements; cash flow or economic evaluations or; feasibility studies, appraisals or valuations.

2.2.8 Furnishing the services of independent professional associates or consultants for work beyond the Scope of Services.

2.2.9 Services necessary due to the Client's award of more than one prime contract for the Project(s); services necessary due to the construction contract containing cost plus or incentive-savings provisions; services necessary in order to arrange for performance by persons other than the prime contractor; or those services necessary to administer Client's contract(s).

2.2.10 Services in connection with staking out the work of contractor(s).

2.2.11 Services during out-of-town travel or visits to the site beyond those specifically identified in this Agreement.

2.2.12 Preparation of operating and maintenance manuals.

2.2.13 Services to redesign some or all of the Project(s).

2.2.14 Preparing to serve or serving as a consultant or witness or assisting Client with any litigation, arbitration or other legal or administrative proceeding.

2.2.15 Services relating to Construction Observation, Certification, Inspection, Construction Cost Estimating, project observation, construction management, construction scheduling, construction phasing or review of Contractor's performance means or methods.

2.3 Whenever, in its sole discretion, Olsson determines additional services as set forth in this Section 2.3 are necessary to avoid a delay in the completion of the Project(s) ("Necessary Additional Services"), Olsson shall perform or obtain from others such services without waiting for specific instructions from Client, and Olsson will be entitled to an increase in compensation for such services at the standard hourly billing rate charged for those employees performing the services, plus reimbursable expenses, if any:

2.3.1 Services in connection with work directive changes and/or change orders directed by the Client to any contractors.

2.3.2 Services in making revisions to drawings and specifications occasioned by the acceptance of substitutions proposed by contractor(s); services after the award of each contract in evaluating and determining the acceptability of an unreasonable or excessive number of substitutions proposed by contractor(s); or evaluating an unreasonable or extensive number of claims submitted by contractor(s) or others in connection with the Project(s).

2.3.3 Services resulting from significant delays, changes or price increases occurring as a direct or indirect result of material, equipment or energy shortages.

2.3.4 Additional or extended services during construction made necessary by (1) work damaged during construction, (2) a defective, inefficient or neglected work by any contractor, (3) acceleration of the progress schedule involving services beyond normal working hours, or (4) default by any contractor.

SECTION 3—CLIENT'S RESPONSIBILITIES

3.1. Client shall provide all criteria and full information as to Client's requirements for the Project(s); designate and identify in writing a person to act with authority on Client's behalf in respect of all aspects of the Project(s); examine and respond promptly to Olsson's submissions; and give prompt written notice to Olsson whenever Client observes or otherwise becomes aware of any defect in the Olsson's services.

3.2 Client agrees to pay Olsson the amounts due for services rendered and expenses within thirty (30) days after Olsson has provided its invoice for such services. In the event Client disputes any invoice item, Client shall give Olsson written notice of such disputed item within fifteen (15) days after receipt of such invoice and shall pay to Olsson the undisputed portion of the invoice according to the provisions hereof. If Client fails to pay any invoiced amounts when due, interest will accrue on each unpaid amount at the rate of thirteen percent (13%) per annum from the date due until paid according to the provisions of this Agreement. Interest shall not be charged on any disputed invoice item which is finally resolved in Client's favor. Payment of interest shall not excuse or cure any default or delay in payment of amounts due.

3.2.1 If Client fails to make any payment due Olsson for services and expenses within thirty (30) days after receipt of Olsson's statement therefore, Olsson may, after giving seven (7) days written notice to Client, suspend services to Client under this Agreement until Olsson has been paid in full all amounts due for services, expenses and charges and Client will not obtain any license to any Work Product or be entitled to retain or use any Work Product pursuant to Section 7.1 unless and until Olsson has been paid in full and Client has fully satisfied all of its obligations under this Agreement.

3.3 Payments to Olsson shall not be withheld, postponed or made contingent on the construction, completion or success of the Project(s) or upon receipt by the Client of offsetting reimbursements or credit from other parties who may have caused the need for additional services. No withholdings, deductions or offsets shall be made from Olsson's compensation for any reason unless and until Olsson has been found to be legally liable for such amounts.

3.4 Client shall also do the following and pay all costs incident thereto:

3.4.1 Furnish to Olsson any existing and/or required borings, probings or subsurface explorations; hydrographic surveys; laboratory tests or inspections of samples, materials or equipment; appropriate professional interpretations of any of the foregoing; environmental assessment and impact statements; property, boundary, easement, right-of-way, topographic or utility surveys; property descriptions; and/or zoning or deed restrictions; all of which Olsson may rely upon in performing services hereunder.

3.4.2 Guarantee access to and make all provisions for Olsson to enter upon public and private property reasonably necessary to perform its services on the Project(s).

3.4.3 Provide such legal, accounting, independent cost estimating or insurance counseling services as may be required for the Project(s); any auditing service required in respect of contractor(s)' applications for payment; and/or any inspection services to determine if contractor(s) are performing the work legally.

3.4.4 Provide engineering surveys to establish reference points for construction unless specifically included in Olsson's Scope of Services.

3.4.5 Furnish approvals and permits from all governmental authorities having jurisdiction over the Project(s).

3.4.6 If more than one prime contractor is to be awarded the contract for construction, designate a party to have responsibility and authority for coordinating and interfacing the activities of the various prime contractors.

3.4.7 All fees and other amounts payable by Client under this Agreement are exclusive of taxes and similar assessments. Without limiting the foregoing, Client is responsible and liable for all sales, service, use, and excise taxes, and any other similar taxes, duties, and charges of any kind imposed by any federal, state, county or local governmental authority on any amounts payable by Client under this Agreement, other than any taxes imposed on Olsson's income. In the event any governmental authority assesses Olsson for taxes, duties, or charges of any kind in connection with Scope of Services provided by Olsson to Client, Olsson shall be entitled to submit an invoice to Client, its successors or assigns, for the amount of said assessment and related interest and penalties. Client shall pay such invoice in accordance with Olsson's standard payment terms.

3.5 Client shall pay all costs incident to obtaining bids or proposals from contractor(s).

3.6 Client shall pay all permit application review costs for government authorities having jurisdiction over the Project(s).

3.7 Contemporaneously with the execution of this Agreement, Client shall designate in writing an individual to act as its duly authorized Project(s) representative.

3.8 Client shall bear sole responsibility for:

3.8.1 Jobsite safety. Neither the professional activities of Olsson, nor the presence of Olsson or its employees or sub-consultants at the Project shall impose any duty on Olsson relating to any health or safety laws, regulations, rules, programs or procedures.

3.8.2 Notifying third parties including any governmental agency or prospective purchaser, of the existence of any hazardous or dangerous materials located in or around the Project(s) site.

3.8.3 Providing and updating Olsson with accurate information regarding existing conditions, including the existence of hazardous or dangerous materials, proposed

Project(s) site uses, any change in Project(s) plans, and all subsurface installations, such as pipes, tanks, cables and utilities within the Project(s) site.

3.8.4 Providing and assuming all responsibility for: interpretation of contract documents; Construction Observations; Certifications; Inspections; Construction Cost Estimating; project observations; construction management; construction scheduling; construction phasing; and review of Contractor's performance, means and methods. Client waives any claims against Olsson and releases Olsson from liability relating to or arising out of such services and agrees, to the fullest extent permitted by law, to indemnify and hold Olsson harmless from any and all damages, liabilities or costs, including reasonable attorneys' fees and defense costs, relating to such actions and services.

3.9 Client releases Olsson from liability for any incorrect advice, judgment or decision based on inaccurate information furnished by Client or others.

3.10 If reasonable precautions will be inadequate to prevent foreseeable bodily injury or death to persons resulting from a material or substance, including hazardous materials, encountered on the site, Olsson may immediately stop work in the affected area and report the condition to Client. Client shall be solely responsible for retaining independent consultant(s) to determine the nature of the material and to abate or remove the material. Olsson shall not be required to perform any services or work relating to or in the area of such material until the material has been removed or rendered harmless and only after approval, if necessary of the government agency with jurisdiction.

SECTION 4—MEANING OF TERMS

4.1 The "Cost of Construction" of the entire Project(s) (herein referred to as "Cost of Construction") means the total cost to Client of those portions of the entire Project(s) designed and specified by Olsson, but it will not include Olsson's compensation and expenses, the cost of land, rights-of-way, or compensation for or damages to, properties unless this Agreement so specifies, nor will it include Client's legal, accounting, insurance counseling or auditing services, or interest and financing charges incurred in connection with the Project(s) or the cost of other services to be provided by others to Client pursuant to Section 3.

4.2 The "Salary Costs": Used as a basis for payment mean salaries and wages (base and incentive) paid to all Olsson's personnel engaged directly on the Project(s), including, but not limited to, engineers, architects, surveyors, designers, draftsmen, specification writers, estimators, other technical and business personnel; plus the cost of customary and statutory benefits, including, but not limited to, social security contributions, unemployment, excise and payroll taxes, workers' compensation, health and retirement benefits, sick leave, vacation and holiday pay and other group benefits.

4.3 "Certify" or "a Certification": If included in the Scope of Services, such services shall be limited to a statement of Olsson's opinion, to the best of Olsson's professional knowledge, information and belief, based upon its periodic observations and reasonable review of reports and tests created by Olsson or provided to Olsson. Olsson shall not be responsible for constant or exhaustive observation of the work. Client

understands and agrees that any certifications based upon discrete sampling observations and that such observations indicate conditions that exist only at the locations and times the observations were performed. Performance of such observation services and certification does not constitute a warranty or guarantee of any type, since even with diligent observation, some construction defects, deficiencies or omissions in the work may occur. Olsson shall have no responsibility for the means, methods, techniques, sequences or procedures selected by the contractor(s) or for the contractor's safety precautions and programs nor for failure by the contractor(s) to comply with any laws or regulations relating to the performance or furnishing of any work by the contractor(s). Client shall hold its contractor(s) solely responsible for the quality and completion of the Project(s), including construction in accordance with the construction documents. Any duty under this Agreement is for the sole benefit of the Client and not for any third party, including the contractor(s) or any subcontractor(s). Olsson shall sign pre-printed form certifications only if (a) Olsson approves the form of such certification prior to the commencement of its services, (b) such certification is expressly included in the Scope of Services, (c) the certification is limited to a statement of professional opinion and does not constitute a warranty or guarantee, express or implied. It is understood that any certification by Olsson shall not relieve the Client or the Client's contractors of any responsibility or obligation they may have by industry custom or under any contract.

4.4 "Opinion of Probable Cost": An opinion of probable construction cost made by Olsson. In providing opinions of probable construction cost, it is recognized that neither the Client nor Olsson has control over the costs of labor, equipment or materials, or over the contractor's methods of determining prices or bidding. The opinion of probable construction costs is based on Olsson's reasonable professional judgment and experience and does not constitute a warranty, express or implied, that the contractor's bids or the negotiated price of the work on the Project(s) will not vary from the Client's budget or from any opinion of probable cost prepared by Olsson.

4.5 "Day": A calendar day of 24 hours. The term "days" shall mean consecutive calendar days of 24 hours each, or fraction thereof.

4.6 "Construction Observation": If included in the Scope of Services, such services during construction shall be limited to periodic visual observation and testing of the work to determine that the observed work generally conforms to the contract documents. Olsson shall not be responsible for constant or exhaustive observation of the work. Client understands and agrees that such visual observations are discrete sampling procedures and that such procedures indicate conditions that exist only at the locations and times the observations were performed. Performance of Construction Observation services does not constitute a warranty or guarantee of any type, since even with diligent observation, some construction defects, deficiencies or omissions in the work may occur. Olsson shall have no responsibility for the means, methods, techniques, sequences or procedures selected by the contractor or for the contractor's safety precautions and programs nor for failure by the contractor to comply with any laws or regulations relating to the performance or furnishing of any work by the contractor. Client shall hold its contractor(s) solely responsible for the quality and completion of the Project(s), including construction in accordance with the construction documents. Any duty under this Agreement is for the sole benefit of the Client and not for

any third party, including the contractor or any subcontractor. Client, or its designees shall notify Olsson at least twenty-four (24) hours in advance of any field tests and observations required by the construction documents.

4.7 "Inspect" or "Inspection": If included in the Scope of Services, such services shall be limited to the periodic visual observation of the contractor's completed work to permit Olsson, as an experienced and qualified professional, to determine that the observed work, generally conforms to the contract documents. Olsson shall not be responsible for constant or exhaustive observation of the work. Client understands and agrees that such visual observations are discrete sampling procedures and that such procedures indicate conditions that exist only at the locations and times the observations were performed. Performance of such observation services does not constitute a warranty or guarantee of any type, since even with diligent observation, some construction defects, deficiencies or omissions in the work may occur. Olsson shall have no responsibility for the means, methods, techniques, sequences or procedures selected by the contractor(s) or for the contractor's safety precautions and programs nor for failure by the contractor(s) to comply with any laws or regulations relating to the performance or furnishing of any work by the contractor(s). Client shall hold its contractor(s) solely responsible for the quality and completion of the Project(s), including construction in accordance with the construction documents. Any duty under this Agreement is for the sole benefit of the Client and not for any third party, including the contractor(s) or any subcontractor(s). Client, or its designees, shall notify Olsson at least twenty-four (24) hours in advance of any inspections required by the construction documents.

4.8 "Record Documents": Drawings prepared by Olsson upon the completion of construction based upon the drawings and other data furnished to Olsson by the Contractor and others showing significant changes in the work on the Project(s) made during construction. Because Record Documents are prepared based on unverified information provided by others, Olsson makes no warranty of the accuracy or completeness of the Record Documents.

SECTION 5—TERMINATION

5.1 Either party may terminate this Agreement, for cause upon giving the other party not less than seven (7) calendar days written notice of default for any of the following reasons; provided, however, that the notified party shall have the same seven (7) calendar day period in which to cure the default:

5.1.1 Substantial failure by the other party to perform in accordance with the terms of this Agreement and through no fault of the terminating party;

5.1.2 Assignment of this Agreement or transfer of the Project(s) by either party to any other entity without the prior written consent of the other party;

5.1.3 Suspension of the Project(s) or Olsson's services by the Client for more than ninety (90) calendar days, consecutive or in the aggregate.

5.2 In the event of a "for cause" termination of this Agreement by either party, the Client shall, within fifteen (15) calendar days after receiving Olsson's final invoice, pay Olsson for all services rendered and all reimbursable costs incurred by

Olsson up to the date of termination, in accordance with the payment provisions of this Agreement.

5.2.1 In the event of a "for cause" termination of this Agreement by Client and (a) a final determination of default is entered against Olsson under Section 6.2 and (b) Client has fully satisfied all of its obligations under this Agreement, Olsson shall grant Client a limited license to use the Work Product pursuant to Section 7.1.

5.3 The Client may terminate this Agreement for the Client's convenience and without cause upon giving Olsson not less than seven (7) calendar days written notice. In the event of any termination that is not the fault of Olsson, the Client shall pay Olsson, in addition to payment for services rendered and reimbursable costs incurred, for all expenses reasonably incurred by Olsson in connection with the orderly termination of this Agreement, including but not limited to demobilization, reassignment of personnel, associated overhead costs, any fees, costs or expenses incurred by Olsson in preparing or negotiating any proposals submitted to Client for Olsson's Scope of Services or Optional Additional Services under this Agreement and all other expenses directly resulting from the termination and a reasonable profit of ten percent (10%) of Olsson's actual costs (including overhead) incurred.

SECTION 6—DISPUTE RESOLUTION

6.1. Mediation

6.1.1 All questions in dispute under this Agreement shall be submitted to mediation. On the written notice of either party to the other of the election to submit any dispute under this Agreement to mediation, each party shall designate their representatives and shall meet within ten (10) days after the service of the notice. The parties themselves shall then attempt to resolve the dispute within ten (10) days of meeting.

6.1.2 Should the parties themselves be unable to agree on a resolution of the dispute, and then the parties shall appoint a third party who shall be a competent and impartial party and who shall be acceptable to each party, to mediate the dispute. Any third party mediator shall be qualified to evaluate the performance of both of the parties, and shall be familiar with the design and construction progress. The third party shall meet to hear the dispute within ten (10) days of their selection and shall attempt to resolve the dispute within fifteen (15) days of first meeting.

6.1.3 Each party shall pay the fees and expenses of the third party mediator and such costs shall be borne equally by both parties.

6.2 Arbitration or Litigation

6.2.1 Olsson and Client agree that from time to time, there may be conflicts, disputes and/or disagreements between them, arising out of or relating to the services of Olsson the Project(s), or this Agreement (hereinafter collectively referred to as "Disputes") which may not be resolved through mediation. Therefore, Olsson and Client agree that all Disputes shall be resolved by binding arbitration or litigation at the sole discretion and choice of Olsson. If Olsson chooses arbitration, the arbitration proceeding shall proceed in accordance with the Construction Industry Arbitration Rules of the AAA.

6.2.2 Client hereby agrees that Olsson shall have the right to include Client, by consolidation, joinder or other manner, in any arbitration or litigation involving Olsson and a subconsultant or subcontractor of Olsson or Olsson and any other person or entity, regardless of who originally initiated such proceedings.

6.2.3 If Olsson chooses arbitration or litigation, either may be commenced at any time prior to or after completion of the Project(s), provided that if arbitration or litigation is commenced prior to the completion of the Project(s), the obligations of the parties under the terms of this Agreement shall not be altered by reason of the arbitration or litigation being conducted. Any arbitration hearings or litigation shall take place in Sapulpa, Oklahoma.

6.2.4 The prevailing party in any arbitration or litigation relating to any Dispute shall be entitled to recover from the other party those reasonable attorney fees, costs and expenses incurred by the prevailing party in connection with the Dispute.

6.3 Certification of Merit

Client agrees that it will not assert any claim, including but not limited to, professional negligence, negligence, breach of contract, misconduct, error, omission, fraud, or misrepresentation ("Claim") against Olsson, or any Olsson subconsultant, unless Client has first provided Olsson with a sworn certificate of merit affidavit setting forth the factual and legal basis for such Claim (the "Certificate"). The Certificate shall be executed by an independent engineer ("Certifying Engineer") currently licensed and practicing in the jurisdiction of the Project site. The Certificate must contain: (a) the name and license number of the Certifying Engineer; (b) the qualifications of the Certifying Engineer, including a list of all publications authored in the previous 10 years and a list of all cases in which the Certifying Engineer testified within the previous 4 years; (c) a statement by the Certifying Engineer setting forth the factual basis for the Claim; (d) a statement by the Certifying Engineer of each and every act, error, or omission that the Certifying Engineer contends supports the Claim or any alleged violation of any applicable standard of care; (e) a statement by the Certifying Engineer of all opinions the Certifying Engineer holds regarding the Claim or any alleged violation of any applicable standard of care; (f) a list of every document related to the Project reviewed by the Certifying Engineer; and (g) a list of every individual who provided Certifying Engineer with any information regarding the Project. The Certificate shall be provided to Olsson not less than thirty (30) days prior to any arbitration or litigation commenced by Client or not less than ten (10) days prior to the initial response submitted by Client in any arbitration or litigation commenced by someone other than Client. The Certificate is a condition precedent to the right of Client to assert any Claim in any litigation or arbitration and Client's failure to timely provide a Certificate to Olsson will be grounds for automatic dismissal of the Claim with prejudice.

SECTION 7—MISCELLANEOUS

7.1 Reuse of Documents

All documents, including drawings, specifications, reports, boring logs, maps, field data, data, test results, information, recommendations, or opinions prepared or furnished by Olsson (and Olsson's independent professional associates and

consultants) pursuant to this Agreement ("Work Product"), are all Olsson's instruments of service, do not constitute goods or products, and are copyrighted works of Olsson. Olsson shall retain an ownership and property interest in such Work Product whether or not the Project(s) is completed. If Client has fully satisfied all of its obligations under this Agreement, Olsson shall grant Client a limited license to use the Work Product and Client may make and retain copies of Work Product for use in connection with the Project(s); however, such Work Product is for the exclusive use and benefit of Client or its agents in connection with the Project(s), are not intended to inform, guide or otherwise influence any other entities or persons with respect to any particular business transactions, and should not be relied upon by any entities or persons other than Client or its agents for any purpose other than the Project(s). Such Work Product is not intended or represented to be suitable for reuse by Client or others on extensions of the Project(s) or on any other Project(s). Client will not distribute or convey such Work Product to any other persons or entities without Olsson's prior written consent which shall include a release of Olsson from liability and indemnification by the third party. Any reuse of Work Product without written verification or adaptation by Olsson for the specific purpose intended will be at Client's sole risk and without liability or legal exposure to Olsson, or to Olsson's independent professional associates or consultants, and Client shall indemnify and hold harmless Olsson and Olsson's independent professional associates and consultants from all claims, damages, losses and expenses including attorneys' fees arising out of or resulting therefrom. Any such verification or adaptation of Work Product will entitle Olsson to further compensation at rates to be agreed upon by Client and Olsson.

7.2 Electronic Files

By accepting and utilizing any electronic file of any Work Product or other data transmitted by Olsson, the Client agrees for itself, its successors, assigns, insurers and all those claiming under or through it, that by using any of the information contained in the attached electronic file, all users agree to be bound by the following terms. All of the information contained in any electronic file is the work product and instrument of service of Olsson, who shall be deemed the author, and shall retain all common law, statutory law and other rights, including copyrights, unless the same have previously been transferred in writing to the Client. The information contained in any electronic file is provided for the convenience to the Client and is provided in "as is" condition. The Client is aware that differences may exist between the electronic files transferred and the printed hard-copy original signed and stamped drawings or reports. In the event of a conflict between the signed original documents prepared by Olsson and the electronic files, which may be transferred, the signed and sealed original documents shall govern. Olsson specifically disclaims all warranties, expressed or implied, including without limitation, and any warranty of merchantability or fitness for a particular purpose with respect to any electronic files. It shall be Client's responsibility to confirm the accuracy of the information contained in the electronic file and that it accurately reflects the information needed by the Client. Client shall not retransmit any electronic files, or any portion thereof, without including this disclaimer as part of any such transmissions. In addition, Client agrees, to the fullest extent permitted by law, to indemnify and hold harmless Olsson, its officers, directors, employees and sub consultants against any and all damages, liabilities, claims or costs, including reasonable attorney's and expert witness fees and defense costs, arising from any changes made by anyone other than

Olsson or from any reuse of the electronic files without the prior written consent of Olsson.

7.3 Opinion of Probable Cost

Since Olsson has no control over the cost of labor, materials, equipment or services furnished by others, or over the contractor(s)' methods of determining prices, or over competitive bidding or market conditions, Olsson's Opinion of Probable Cost provided for herein is made on the basis of Olsson's experience and qualifications and represent Olsson's best judgment as an experienced and qualified professional engineer, familiar with the construction industry. Client acknowledges and agrees that Olsson cannot and does not guarantee proposals or bids and that actual total Project(s) or construction costs may reasonably vary from Olsson's Opinion of Probable Cost. If prior to the bidding or negotiating phase Client wishes greater assurance as to total Project(s) or construction costs, Client shall employ an independent cost estimator as provided in paragraph 3.4.3. If Olsson's Opinion of Probable Cost was performed in accordance with its standard of care and was reasonable under the total circumstances, any services performed by Olsson to modify the contract documents to bring the construction cost within any limitation established by Client will be considered Optional Additional Services and paid for as such by Client. If, however, Olsson's Opinion of Probable Cost was not performed in accordance with its standard of care and was unreasonable under the total circumstances and the lowest negotiated bid for construction of the Project(s) unreasonably exceeds Olsson's Opinion of Probable Cost, Olsson shall modify its work as necessary to adjust the Project(s)' size, and/or quality to reasonably comply with the Client's budget at no additional cost to Client. Under such circumstances, Olsson's modification of its work at no cost shall be the limit of Olsson's responsibility with regard to any unreasonable Opinion of Probable Cost.

7.4 Prevailing Wages

It is Client's responsibility to determine whether the Project(s) is covered under any prevailing wage regulations. Unless Client specifically informs Olsson in writing that the Project(s) is a prevailing wage project and is identified as such in the Scope of Services, Client agrees to reimburse Olsson and to defend, indemnify and hold harmless Olsson from and against any liability, including costs, fines and attorneys' fees, resulting from a subsequent determination that the Project(s) was covered under any prevailing wage regulations.

7.5 Samples

All material testing samples shall remain the property of the Client. If appropriate, Olsson shall preserve samples obtained no longer than forty-five (45) days after the issuance of any document that includes the data obtained from those samples. After that date, Olsson may dispose of the samples or return them to Client at Client's cost.

7.6 Standard of Care

Olsson will strive to perform its services in a manner consistent with that level of care and skill ordinarily exercised by members of Olsson's profession providing similar services in the same locality under similar circumstances at the time Olsson's services are performed. This Agreement creates no other representation, warranty or guarantee, express or implied.

7.7 Force Majeure

Any delay in the performance of any of the duties or obligations of either party hereto (except the payment of money) shall not be considered a breach of this Agreement and the time required for performance shall be extended for a period equal to the period of such delay, provided that such delay has been caused by or is the result of any acts of God, acts of the public enemy, insurrections, riots, embargoes, labor disputes, including strikes, lockouts, job actions, boycotts, fires, explosions, floods, shortages of material or energy, or other unforeseeable causes beyond the control and without the fault or negligence of the party so affected. The affected party shall give prompt notice to the other party of such cause, and shall take promptly whatever reasonable steps are necessary to relieve the effect of such cause.

7.8 Equal Employment Opportunity

Olsson and any sub-consultant or subcontractor shall abide by the requirements of 41 CFR 60-1.4(a), 60-300.5(a) and 60-741.5(a). These regulations prohibit discrimination against qualified individuals based on their status as protected veterans or individuals with disabilities, and prohibit discrimination against all individuals based on their race, color, religion, sex, sexual orientation, gender identity or national origin. Moreover, these regulations require that covered prime contractors and subcontractors take affirmative action to employ and advance in employment individuals without regard to race, color, religion, sex, sexual orientation, gender identity, national origin, disability or veteran status.

7.9 Confidentiality

In performing this Agreement, the parties may disclose to each other written, oral, electronic, graphic, machine-readable, tangible or intangible, non-public, confidential or proprietary data or information in any form or medium, including but not limited to: (1) information of a business, planning, marketing, conceptual, design, or technical nature; (2) models, tools, hardware, software or source code; and (3) any documents, videos, photographs, audio files, data, studies, reports, flowcharts, works in progress, memoranda, notes, files or analyses that contain, summarize or are based upon any non-public, proprietary or confidential information (hereafter referred to as the "Information"). The Information is not required to be marked as confidential.

7.9.1 Therefore, Olsson and Client agree that the party receiving Information from the other party to this Agreement (the "Receiving Party") shall keep Information confidential and not use the Information in any manner other than in the performance of this Agreement without prior written approval of the party disclosing Information (the "Disclosing Party") unless Client is a public entity and the release of Information is required by law or legal process.

7.9.2 Prior to the start of construction on the Project, the existence of discussions between the parties, the purpose of this Agreement, and this Agreement shall be considered Information subject to the confidentiality provisions of this Agreement.

7.9.3 Notwithstanding anything to the contrary herein, the Receiving Party shall have no obligation to preserve the confidentiality of any Information which:

7.9.3.1 was previously known to the Receiving Party free of any obligation to keep it confidential; or

7.9.3.2 is or becomes publicly available by other than unauthorized disclosures; or

7.9.3.3 is independently developed by the Receiving Party without a breach of this Agreement; or

7.9.3.4 is disclosed to third parties by the Disclosing Party without restrictions; or

7.9.3.5 is received from a third party not subject to any confidentiality obligations.

7.9.4 In the event that the Receiving Party is required by law or legal process to disclose any of Information of the Disclosing Party, the Receiving Party required to disclose such Information shall provide the Disclosing Party with prompt oral and written notice, unless notice is prohibited by law (in which case such notice shall be provided as early as may be legally permissible), of any such requirement so that the Disclosing Party may seek a protective order or other appropriate remedy.

7.9.5 Notwithstanding anything to the contrary herein (or to the contrary of any existing or future nondisclosure, confidentiality or similar agreement between the parties), Olsson is authorized, to use, display, reproduce, publish, transmit, and distribute Information (including, but not limited to, videos and photographs of the Project) on and in any and all formats and media (including, but not limited to, Olsson's internet website) throughout the world and in all languages in connection with or in any manner relating to the marketing, advertising, selling, qualifying, proposing, commercializing, and promotion of Olsson and/or its services and business and in connection with any other lawful purpose of Olsson. In the event of any conflict or inconsistency between the provisions of this section and any other prior or future nondisclosure, confidentiality or similar agreement between the parties, the terms of this section shall take precedence.

7.9.6 Nothing contained in this Agreement shall be construed as altering any rights that the Disclosing Party has in the Information exchanged with or disclosed to the Receiving Party, and upon request, the Receiving Party will return all Information received in tangible form to the Disclosing Party, or at the Receiving Party's option, destroy all such Information. If the Receiving Party exercises its option to destroy the Information, the Receiving Party shall certify such destruction to the Disclosing Party.

7.9.7 The parties acknowledge that disclosure or use of Information in violation of this Agreement could cause irreparable harm for which monetary damages may be difficult to ascertain or constitute an inadequate remedy. Each party therefore agrees that the Disclosing Party shall be entitled in addition to its other rights to seek injunctive relief for any violation of this Agreement.

7.9.8 The obligations of confidentiality set forth herein shall survive termination of this Agreement but shall only remain in effect for a period of one (1) year from the date the Information is first disclosed.

7.10 Damage or Injury to Subterranean Structures or Utilities, Hazardous Materials, Pollution and Contamination

7.10.1 To the extent that work pursuant to this Agreement requires any sampling, boring, excavation, ditching or other disruption of the soil or subsurface at the Site, Olsson shall confer with Client prior to such activity and Client will be responsible for identifying, locating and marking, as necessary, any private subterranean structures or utilities and Olsson shall be responsible for arranging investigation of public subterranean structures or utilities through an appropriate utility one-call provider. Thereafter, Olsson shall take all reasonable precautions to avoid damage or injury to subterranean structures or utilities which were identified by Client or the one-call provider. Olsson shall not be responsible for any damage, liability or costs, for any property damage, injury or economic loss arising or allegedly arising from damages to subterranean structures or utilities caused by subsurface penetrations in locations approved by Client and/or the one call provider or not correctly shown on any plans, drawings or utility clearance provided to Olsson, except for damages caused by the negligence of Olsson in the use of such information.

7.10.2 It is understood and agreed that any assistance Olsson may provide Client in the disposal of waste materials shall not result in Olsson being deemed as a generator, arranger, transporter or disposer of hazardous materials or hazardous waste as defined under any law or regulation. Title to all samples and waste materials remains with Client, and at no time shall Olsson take title to the above material. Client may authorize Olsson to execute Hazardous Waste Manifest, Bill of Lading or other forms as agent of Client. If Client requests Olsson to execute such documents as its agent, the Hazardous Waste Manifest, Bill of Lading or other similar documents shall be completed in the name of the Client. Client agrees to indemnify and hold Olsson harmless from any and all claims that Olsson is a generator, arranger, transporter, or disposer of hazardous waste as a result of any actions of Olsson, including, but not limited to, Olsson signing a Hazardous Waste Manifest, Bill of Lading or other form on behalf of Client.

7.10.3 At any time, Olsson can request in writing that Client remove samples, cuttings and hazardous substances generated by the Project(s) from the project site or other location. Client shall promptly comply with such request, and pay and be responsible for the removal and lawful disposal of samples, cuttings and hazardous substances, unless other arrangements are mutually agreed upon in writing.

7.10.4 Client shall release Olsson of any liability for, and shall defend and indemnify Olsson against any and all claims, liability and expense resulting from operations under this Agreement on account of injury to, destruction of, or loss or impairment of any property right in or to oil, gas, or other mineral substance or water, if at the time of the act or omission causing such injury, destruction, loss or impairment, said substance had not been reduced to physical possession above the surface of the earth, and for any loss or damage to any formation, strata, reservoir beneath the surface of the earth.

7.10.5 Notwithstanding anything to the contrary contained herein, it is understood and agreed by and between Olsson and Client that the responsibility for pollution and contamination shall be as follows:

7.10.5.1 Unless otherwise provided herein, Client shall assume all responsibility for, including control and removal of, and protect, defend and save harmless Olsson from and against all claims, demands and causes of action of every kind and character arising from pollution or contamination (including naturally occurring radioactive material) which originates above the surface of the land or water from spills of fuels, lubricants, motor oils, pipe dope, paints, solvents, ballast, bilge and garbage, except unavoidable pollution from reserve pits, wholly in Olsson's possession and control and directly associated with Olsson's equipment.

7.10.5.2 In the event a third party commits an act or omission which results in pollution or contamination for which either Olsson or Client, for whom such party is performing work, is held to be legally liable, the responsibility therefore shall be considered as between Olsson and Client, to be the same as if the party for whom the work was performed had performed the same and all of the obligations regarding defense, indemnity, holding harmless and limitation of responsibility and liability, as set forth herein, shall be specifically applied.

7.11 Controlling Law and Venue

The parties agree that this Agreement and any legal actions concerning its validity, interpretation or performance shall be governed by the laws of the State of Nebraska. It is further agreed that any legal action between the parties arising out of this Agreement or the performance of services shall be brought in a court of competent jurisdiction in Nebraska.

7.12 Subconsultants

Olsson may utilize as necessary in its discretion subconsultants and other subcontractors. Olsson will be paid for all services rendered by its subconsultants and other subconsultants as set forth in this Agreement.

7.13 Assignment

7.13.1 Client and Olsson each are hereby bound and the partners, successors, executors, administrators and legal representatives of Client and Olsson (and to the extent permitted by paragraph 7.13.2 the assigns of Client and Olsson) are hereby bound to the other party to this Agreement and to the partners, successors, executors, administrators and legal representatives (and said assigns) of such other party, in respect of all covenants, agreements and obligations of this Agreement.

7.13.2 Neither Client nor Olsson shall assign, sublet or transfer any rights under or interest in (including, but without limitation, moneys that may become due or moneys that are due) this Agreement without the written consent of the other, except to the extent that any assignment, subletting or transfer is mandated by law or the effect of this limitation may be restricted by law. Unless specifically stated to the contrary in any written consent to an assignment, no assignment will release or discharge the assignor from any duty or responsibility under this Agreement. Nothing contained in this paragraph shall prevent Olsson from employing such subconsultants and other subcontractors as Olsson may deem appropriate to assist in the performance of services under this Agreement.

7.13.3 Nothing under this Agreement shall be construed to give any rights or benefits in this Agreement to

anyone other than Client and Olsson, and all duties and responsibilities undertaken pursuant to this Agreement will be for the sole and exclusive benefit of Client and Olsson and not for the benefit of any other party. There are no third-party beneficiaries of this Agreement.

7.14 Indemnity

Olsson and Client mutually agree, to the fullest extent permitted by law, to indemnify and hold each other harmless from any and all damages, liabilities or costs, including reasonable attorneys' fees and defense costs, relating to third party personal injury or third party property damage and arising from their own negligent acts, errors or omissions in the performance of their services under this Agreement, but only to the extent that each party is responsible for such damages, liabilities or costs on a comparative basis of fault.

7.15 Limitation on Damages

7.15.1 Notwithstanding any other provision of this Agreement, and to the fullest extent permitted by law, neither party's individual employees, principals, officers or directors shall be subject to personal liability or damages arising out of or connected in any way to the Project(s) or to this Agreement.

7.15.2 Notwithstanding any other provision of this Agreement, and to the fullest extent permitted by law, neither Client nor Olsson, their respective officers, directors, partners, employees, contractors or subconsultants shall be liable to the other or shall make any claim for any delay damages, any punitive damages or any incidental, indirect or consequential damages arising out of or connected in any way to the Project(s) or to this Agreement. This mutual waiver of delay damages and consequential damages shall include, but is not limited to, disruptions, accelerations, inefficiencies, increased construction costs, increased home office overhead, loss of use, loss of profit, loss of business, loss of income, loss of reputation or any other delay or consequential damages that either party may have incurred from any cause of action including, but not limited to, negligence, statutory violations, misrepresentation, fraud, deceptive trade practices, breach of fiduciary duties, strict liability, breach of contract and/or breach of strict or implied warranty. Both the Client and Olsson shall require similar waivers of consequential damages protecting all the entities or persons named herein in all contracts and subcontracts with others involved in the Project(s).

7.15.3 Notwithstanding any other provision of this Agreement, Client agrees that, to the fullest extent permitted by law, Olsson's total liability to the Client for any and all injuries, claims, losses, expenses, damages, or claims expenses of any kind arising from any services provided by or through Olsson under this Agreement, shall not exceed the amount of Olsson's fee earned under this Agreement. Client acknowledges that such causes include, but are not limited to, negligence, statutory violations, misrepresentation, fraud, deceptive trade practices, breach of fiduciary duties, strict liability, breach of contract and/or breach of strict or implied warranty. This limitation of liability shall apply to all phases of Olsson's services performed in connection with the Project(s), whether subsequent to or prior to the execution of this Agreement.

7.16 Entire Agreement

This Agreement supersedes all prior communications, understandings and agreements, whether oral or written. Amendments to this Agreement must be in writing and signed by the Client and Olsson.

General Provisions updated 04/15/2020.

SCOPE OF SERVICES

This exhibit is hereby attached to and made a part of the Letter Agreement for Professional Services dated March 10, 2020 between the City of Sapulpa, Oklahoma (“Client”) and Olsson, Inc. dba Ochsner Hare & Hare the Olsson Studio (“Olsson”) providing for professional services. Olsson’s Scope of Services for the Agreement is indicated below.

PROJECT DESCRIPTION AND LOCATION

Project will be located at: Sapulpa, Oklahoma

Project Description: Downtown Sapulpa Master Plan

SCOPE OF SERVICES

Olsson shall provide the following services (Scope of Services) to Client for the Project:

Phase 100 - Project Kickoff, Management, and Progress Meetings

Olsson will provide Project management coordination, quality/cost control, information coordination, and Project schedules.

Olsson will attend one (1) kickoff meeting in Sapulpa, Oklahoma, to define expectations and clarify Project goals. Olsson shall review Project scope, schedule, public engagement strategy, and stakeholder and technical committee responsibilities.

Client shall coordinate formation of, outreach to, communication with, and management of stakeholder and technical committees. Client shall communicate Project information to the broader public, as required.

Stakeholder committee shall include key property owners, business owners, and residents. The ideal size for the stakeholder committee is 30 to 40 people. The technical committee shall include City staff members and representatives from various agencies and departments.

Deliverables: Project kickoff meeting materials

Meetings: One (1) Project kickoff meeting in Sapulpa, Oklahoma

Phase 200 – Branding and Discovery

Olsson will prepare a branding plan that details logo, colors, fonts, and theming for Project, to be integrated into all print and digital materials, with guidance from Client.

Olsson and Client shall establish Project boundary geographical limits prior to mapping.

Client will provide Olsson with existing conditions data, including:

- GIS data:
 - Parcels
 - City and downtown boundaries
 - Existing and future land use

- Existing zoning
- Special use districts and overlay zones
- Utility locations/networks
- Transportation networks (all modes)
- Natural features, including floodplain/floodway, waterbodies, wetlands, open space, tree masses, greenways, et cetera
- Public facilities, including fire and police stations, schools, libraries, et cetera
- Planimetric data (pavement edges, sidewalks, parking lots, building footprints, et cetera)
- Available economic development data (vacancy/occupancy rates, building permits awarded, et cetera)
- Census and other relevant data for Project site, City of Sapulpa, and the larger market service area; specifically, demographics, housing, and economics

Olsson will comprehensively map data to analyze downtown Sapulpa and trends to determine impacts on master planning.

Visualization tools will map a wide range of data sets for downtown. Olsson will coordinate with City staff to collect and review all applicable plan documents and development regulations. Olsson shall review the following documents:

- “Plan Sapulpa” Connecting to the Future: Sapulpa, Oklahoma 2030 Comprehensive Plan (2014)
- Zoning regulations
- Subdivision regulations

Olsson shall supplement data with one (1) field visit of Project site to analyze current conditions and take photographs. Photographic inventory will document quality and conditions of the built environment, development patterns, traffic and parking patterns, and downtown aesthetics and character.

Economic Analysis and Market Positioning Strategy

Olsson will conduct an economic analysis of Project site to formulate a “market positioning strategy”. Key economic analysis tasks include evaluating current and future economic and market factors; and conditions that influence existing and future business and development opportunities.

Olsson shall provide the following in the economic analysis:

- Primary market area within Project site and other business/development site locations within the market area.
- Demographic trends impacting downtown’s development potential. Olsson will gather the following demographic data for the primary market area, as defined by Olsson, for use in the study:
 - Population trends
 - Household income
 - Building permits
 - Employment growth rates
 - Household growth rates
- Local real estate development patterns and growth trends that indicate market demand for a variety of uses within Project location. Olsson will gather development permit data for the study.

- Uses for which there is (or will be) demonstrated demand which will seek development sites with attributes similar to those offered in Project location.
- Project's location in context of other areas and development trends and patterns previously identified within the primary market area. Olsson will gather the following data:
 - Competing retail/commercial centers
 - Competing employment centers
 - Competing residential centers
- Other factors that may bear upon Project's competitive position, including zoning, development standards, et cetera.
- Economic analysis comparison of Project location with other sites to evaluate advantages and disadvantages.
- Recommendations for how to competitively position Project area within its broader market area.
- Forecast demand for commercial, office, residential, industrial, and mixed uses in Project area.
- Market positioning strategy's findings and recommendations to be integrated into the plan.

Transportation and Parking Analysis

Olsson will assemble available traffic volume counts (peak hour turning movements, if available) from existing sources, including Oklahoma Department of Transportation, City of Sapulpa, and/or Indian Nations Council of Governments. New traffic counts are not included in this Scope of Services.

Olsson will assess existing transportation network on a qualitative basis using industry standards for overall capacity and performance. Olsson will summarize parking inventory for the Project area, including the number of spaces available on-street, off-street, and any parking restrictions. Ownership for off-street parking will also be documented. If available, parking usage and turnover rates will be documented. Detailed parking counts or turnover study are not included in this Scope of Services. Olsson assumes this information will be provided by Others (city staff members, business community, et cetera).

Olsson will summarize existing employment (retail, office, restaurant, and other) and population by city block within Project area. Olsson assumes this information will be provided by Others (city staff members, business community, et cetera).

Olsson will develop a parking model to estimate future development demands for available parking supply.

Olsson will document trip generation and parking needs based on results of the economic analysis and market positioning strategy. This information will identify potential transportation and parking needs for new investments and development.

Deliverables: Branding plan; draft of Section 1 - Introduction and Section 2 - Downtown Snapshot; and draft of Downtown Economic Analysis and Market Positioning Strategy

Meetings: None

Phase 300 - Marketing, Engagement, and Concept Planning

Marketing

Olsson will coordinate with Client for content and timing of up to four (4) press releases throughout the planning process. Client will be responsible for writing and distributing press releases to local media outlets.

Olsson will create a postcard-size mailer for Client to send to all City residents. Mailer will include a Project overview, a link to the Project website, and list of ways to get involved. Client will be responsible for compiling the distribution list, printing and postage costs, and mailing the mailer.

Client will coordinate with City's existing social media platforms and the City's website to encourage engagement in the planning process. Client will be responsible for drafting and posting Project-related content on the City's website and social media accounts. Olsson will coordinate with Client on content and timing of website and social media posts.

Online Engagement

Olsson will prepare a dedicated Project website for Project information. This website will allow interested participants to view and provide feedback; and learn how to get involved in the planning process. Olsson will maintain website operations, updates, monitoring, and maintenance throughout the planning process; and will transfer all website operations and update authority to Client once planning process is complete.

Olsson will work with Client to develop questions for a public survey to be integrated into the Project website. Survey will focus on high-level priorities; and Client shall advertise the survey through social media platforms, website, and press releases.

In-Person Engagement

Olsson will conduct a half-day visioning workshop for the Project stakeholder committee, technical committee, and Client. This workshop will develop an initial vision and set of Project guiding principles. Workshop will include facilitated small-group discussions and review sessions with the larger group. Olsson will organize a series of interactive exercises for participants.

Following the visioning workshop, Olsson will review themes that emerged and prepare a summary, a vision statement, and guiding principles.

Olsson will host a three (3)-day design charrette to develop future land uses, development/redevelopment opportunities, traffic flow and parking improvements, and streetscape/aesthetic enhancements. Olsson will prepare imagery, graphics, analysis mapping, and preliminary planning concepts for discussion and feedback. Based on reactions received, Olsson will explore planning and design solutions for the Project location, addressing land use, transportation, parking, sustainability, aesthetics, development and redevelopment, market, and economics. These solutions will be hand-drawn.

The charrette will include a series of stakeholder and technical committee progress sessions, preference and visioning exercises, and ongoing planning and design sessions. The charrette will include a public open house (public open house #1) for community members to view progress from the charrette and share feedback.

Client shall provide a workshop meeting space and pay required reservation fees for the design charrette. Space requirements include:

- Room shall accommodate at least 40 people
- Ample blank wall space (no windows preferred)
- Walls without art and other attached materials
- Walls that painters' tape may be affixed to
- Layout tables that can be moved into various arrangements
- Chairs for the tables
- Electrical outlets
- Wi-Fi
- Secured at night so all materials can be left out on walls and tables
- Allow Olsson access from, at a minimum, 7:30 AM to 6:00 PM
- No other events scheduled to use space during the workshop at any time, day or night

Following public open house #1, Olsson shall evaluate preferred concepts generated in the charrette and align with goals and objectives identified in the visioning workshop.

Once a draft master plan has been reviewed by Client, Sapulpa Metropolitan Area Planning Commission, and the City Council; a second public open house (public open house #2) will be conducted by Olsson. Prior to public open house #2, but on the same day, Olsson will host a "first look" stakeholder and technical committee meeting.

Open houses may be conducted in the same facility as the charrette, depending on size, availability, and accommodation. Olsson will coordinate with Client for open house space requirements.

Deliverables: Visioning workshop summary; Project website with integrated survey; one (1) postcard mailer; and draft of Section 3 - Community Engagement

Meetings: One (1) visioning workshop; one (1) design charrette; two (2) public open houses; and one (1) stakeholder and technical committee meeting

Phase 400 - Plan Development

Olsson will create a series of actionable recommendations and implementation strategies. The plan will address land use, development/redevelopment, transportation flow, parking improvements, green space, sustainability, natural features, streetscape enhancements, and economic development.

Plan document will be illustrative, including annotated plan graphics and photographic imagery.

Deliverables: Draft of recommendations sections

Meetings: None

Phase 500 - Plan Refinement

Client will provide a single PDF document of comments for draft recommendations to be addressed. Olsson will submit a revised draft plan for use at one (1) work session with Sapulpa Metropolitan Area Planning Commission and one (1) work session with City Council. Client will present the draft plan at each work session and send a single PDF document of comments to be addressed on draft recommendations.

Following two work sessions, Olsson will revise the draft plan and prepare materials for the public open house #2, as previously described.

Following public open house #2, Olsson will virtually meet with Client to discuss received comments and determine a final list of revisions to be incorporated into the draft plan.

Olsson will draft the final section – implementation strategies – and submit to Client for review. Olsson will develop supporting implementation strategies for recommendations, including planning-level estimates of probable cost for transportation, parking, and streetscape improvements. Client will provide a single PDF document of comments for implementation strategies to be addressed. Olsson will submit a revised, complete, and final plan to be presented at a Sapulpa Metropolitan Area Planning Commission meeting and City Council meeting. Client will present the comprehensive plan at both formal commission meetings for approval and adoption.

Deliverables: Draft of complete Downtown Sapulpa Master Plan in PDF file format; final version of complete Downtown Sapulpa Master Plan with appendices in PDF file format

Meetings: One (1) virtual comment review meeting with Client

ASSUMPTIONS

- If Project Scope of Services or schedule change for any reason, Olsson will coordinate with Client to review and amend fees, as required, to align with revised scope and/or schedule.
- All services shall be completed one (1) time only. Repetition of any tasks, beyond normal design/review processes, or as noted in the Scope of Services, shall be considered as additional services.
- Existing employment and population by block within the Project area will be provided by Others

EXCLUSIONS

The following services are not included in this Scope of Services but can be provided by Olsson under a separate Agreement, if requested:

- Detailed parking counts or turnover study
- Hard copies of Downtown Sapulpa Master Plan
- Construction drawings
- As-built drawings/certifications
- Field and construction services, including construction staking, testing, and observation
- Permit fees
- Project-related permitting
- Easement legal descriptions and exhibits

Should Client request work in addition to the Scope of Services, Olsson shall invoice Client for such additional services (Optional Additional Services) at the standard hourly billing labor rate charged for those employees actually performing the work, plus reimbursable expenses if any. Olsson shall not commence work on Optional Additional Services without Client's prior written approval.

Olsson agrees to provide all of its services in a timely, competent and professional manner, in accordance with applicable standards of care, for projects of similar geographic location, quality and scope.



AGENDA ITEM

Administration 11. G.

City Council Regular

Meeting Date: April 20, 2020

Submitted By: Mark Stephens, Inspection Division Supervisor

Department: Building Inspections & Safety

Presented By: Mark Stephens

SUBJECT:

Discussion and possible action regarding modified Agreement with ESRI to expand the City's current licensing to provide ArcGIS Mapping for the City of Sapulpa at an additive cost amount of \$4,030.00.

BACKGROUND:

Currently, the City has contracted licenses with ESRI for the Urban Development Department and Sapulpa Police/Fire to provide ArcGIS software and support. We also contract with another vendor to provide Online mapping to several other departments within the City under the Storm Water Management Department. We have negotiated with ESRI to expand and enhance our existing contract by moving to the Small Government licensing platform. This will increase our annual expense to ESRI by \$4,000 but will allow unlimited desktop licenses and 100 field licenses without impacting any existing systems. This also eliminates the secondary vendor requirement that had an annual cost of over \$20,000. This is a 3-year contract commitment but only if the Council elects to appropriate funding in subsequent fiscal years.

RECOMMENDATION:

Staff recommendation Council approve Agreement.

Fiscal Impact

Amount: \$4,030.00

To be paid from: Stormwater Management Fund

Account number: 29-529-354

Attachments

Agreement



March 16, 2020

Mark Stephens
City of Sapulpa
425 E Dewey St
Sapulpa, OK 74067

Dear Mark,

The Esri Small Municipal and County Government Enterprise Agreement (SGEA) is a three-year agreement that will grant your organization access to Esri term license software. The EA will be effective on the date executed and will require a firm, three-year commitment.

Based on Esri's work with several organizations similar to yours, we know there is significant potential to apply Geographic Information System (GIS) technology in many operational and technical areas within your organization. For this reason, we believe that your organization will greatly benefit from an Enterprise Agreement (EA).

An EA will provide your organization with numerous benefits including:

- A lower cost per unit for licensed software
- Substantially reduced administrative and procurement expenses
- Complete flexibility to deploy software products when and where needed

The following business terms and conditions will apply:

- All current departments, employees, and in-house contractors of the organization will be eligible to use the software and services included in the EA.
- If your organization wishes to acquire and/or maintain any Esri software during the term of the agreement that is not included in the EA, it may do so separately at the Esri pricing that is generally available for your organization for software and maintenance.
- The organization will establish a single point of contact for orders and deliveries and will be responsible for redistribution to eligible users.
- The organization will establish a Tier 1 support center to field calls from internal users of Esri software. The organization may designate individuals as specified in the EA who may directly contact Esri for Tier 2 technical support.
- The organization will provide an annual report of installed Esri software to Esri.
- Esri software and updates that the organization is licensed to use will be automatically available for downloading.
- The fee and benefits offered in this EA proposal are contingent upon your acceptance of Esri's Small Municipal and County Government EA terms and conditions.

- Licenses are valid for the term of the EA.

This program offer is valid for 90 days. To complete the agreement within this time frame, please contact me within the next seven days to work through any questions or concerns you may have.

To expedite your acceptance of this EA offer:

1. Sign and return the EA contract with a Purchase Order or issue a Purchase Order that references this EA Quotation and includes the following statement on the face of the Purchase Order:

"THIS PURCHASE ORDER IS GOVERNED BY THE TERMS AND CONDITIONS OF THE ESRI SMALL MUNICIPAL AND COUNTY GOVERNMENT EA, AND ADDITIONAL TERMS AND CONDITIONS IN THIS PURCHASE ORDER WILL NOT APPLY."

Have it signed by an authorized representative of the organization.

2. On the first page of the EA, identify the central point of contact/agreement administrator. The agreement administrator is the party that will be the contact for management of the software, administration issues, and general operations. Information should include name, title (if applicable), address, phone number, and e-mail address.
3. In the purchase order, identify the "Ship to" and "Bill to" information for your organization.
4. Send the purchase order and agreement to the address, email or fax noted below:

Esri
Attn: Customer Service SG-EA
380 New York Street
Redlands, CA 92373-8100

e-mail: service@esri.com
fax documents to: 909-307-3083

I appreciate the opportunity to present you with this proposal, and I believe it will bring great benefits to your organization.

Thank you very much for your consideration.

Best Regards,

Sean Gill



Quotation # Q-410695

Date: March 16, 2020

Customer # 265504 Contract #

City of Sapulpa
Urban Development Dept
425 E Dewey St
Sapulpa, OK 74067

ATTENTION: Mark Stephens
PHONE: (918) 248-5909
EMAIL: mstephens@cityofsapulpa.net

Environmental Systems Research Institute, Inc.
380 New York St
Redlands, CA 92373-8100
Phone: (909) 793-2853 Fax: (909) 307-3049
DUNS Number: 06-313-4175 CAGE Code: OAMS3

To expedite your order, please attach a copy of this quotation to your purchase order.
Quote is valid from: 3/16/2020 To: 6/14/2020

Material	Qty	Term	Unit Price	Total
168177	1	Year 1	\$4,030.00	\$4,030.00
Populations of 0 to 25,000 Small Government Term Enterprise License Agreement				
Year 1 to conclude on 10/31/20				
168177	1	Year 2	\$27,500.00	\$27,500.00
Populations of 0 to 25,000 Small Government Term Enterprise License Agreement				
11/1/20 - 10/31/21				
168177	1	Year 3	\$27,500.00	\$27,500.00
Populations of 0 to 25,000 Small Government Term Enterprise License Agreement				
11/1/21 - 10/31/22				

Esri may charge a fee to cover expenses related to any customer requirement to use a proprietary vendor management, procurement, or invoice program.

For questions contact: Sean Gill	Email: s.gill@esri.com	Phone: (909) 793-2853 x8828
<p>The items on this quotation are subject to and governed by the terms of this quotation, the most current product specific scope of use document found at https://assets.esri.com/content/dam/esrisites/media/legal/product-specific-terms-of-use/e300.pdf, and your applicable signed agreement with Esri. If no such agreement covers any item quoted, then Esri's standard terms and conditions found at https://go.esri.com/MAPS apply to your purchase of that item. Federal government entities and government prime contractors authorized under FAR 51.1 may purchase under the terms of Esri's GSA Federal Supply Schedule. Supplemental terms and conditions found at https://www.esri.com/en-us/legal/terms/state-supplemental apply to some state and local government purchases. All terms of this quotation will be incorporated into and become part of any additional agreement regarding Esri's offerings. Acceptance of this quotation is limited to the terms of this quotation. Esri objects to and expressly rejects any different or additional terms contained in any purchase order, offer, or confirmation sent to or to be sent by buyer. Unless prohibited by law, the quotation information is confidential and may not be copied or released other than for the express purpose of system selection and purchase/license. The information may not be given to outside parties or used for any other purpose without consent from Esri. Delivery is FOB Origin.</p>		

GILLS

This offer is limited to the terms and conditions incorporated and attached herein.



Quotation # Q-410695

Date: March 16, 2020

Customer # 265504 Contract #

City of Sapulpa
Urban Development Dept
425 E Dewey St
Sapulpa, OK 74067

ATTENTION: Mark Stephens
PHONE: (918) 248-5909
EMAIL: mstephens@cityofsapulpa.net

Environmental Systems Research Institute, Inc.
380 New York St
Redlands, CA 92373-8100
Phone: (909) 793-2853 Fax: (909) 307-3049
DUNS Number: 06-313-4175 CAGE Code: 0AMS3

To expedite your order, please attach a copy of this quotation to your purchase order.
Quote is valid from: 3/16/2020 To: 6/14/2020

Subtotal:	\$59,030.00
Sales Tax:	\$0.00
Estimated Shipping and Handling (2 Day Delivery):	\$0.00
Contract Price Adjust:	\$0.00
Total:	\$59,030.00

Esri may charge a fee to cover expenses related to any customer requirement to use a proprietary vendor management, procurement, or invoice program.

For questions contact: Sean Gill	Email: s.gill@esri.com	Phone: (909) 793-2853 x8828
<p>The items on this quotation are subject to and governed by the terms of this quotation, the most current product specific scope of use document found at https://assets.esri.com/content/dam/esrisites/media/legal/product-specific-terms-of-use/e300.pdf, and your applicable signed agreement with Esri. If no such agreement covers any item quoted, then Esri's standard terms and conditions found at https://go.esri.com/MAPS apply to your purchase of that item. Federal government entities and government prime contractors authorized under FAR 51.1 may purchase under the terms of Esri's GSA Federal Supply Schedule. Supplemental terms and conditions found at https://www.esri.com/en-us/legal/terms/state-supplemental apply to some state and local government purchases. All terms of this quotation will be incorporated into and become part of any additional agreement regarding Esri's offerings. Acceptance of this quotation is limited to the terms of this quotation. Esri objects to and expressly rejects any different or additional terms contained in any purchase order, offer, or confirmation sent to or to be sent by buyer. Unless prohibited by law, the quotation information is confidential and may not be copied or released other than for the express purpose of system selection and purchase/license. The information may not be given to outside parties or used for any other purpose without consent from Esri. Delivery is FOB Origin.</p>		

GILLS

This offer is limited to the terms and conditions incorporated and attached herein.

Esri Use Only:

Cust. Name _____
Cust. # _____
PO # _____
Esri Agreement # _____



**SMALL ENTERPRISE AGREEMENT
COUNTY AND MUNICIPALITY GOVERNMENT
(E214-1)**

This Agreement is by and between the organization identified in the Quotation ("**Customer**") and **Environmental Systems Research Institute, Inc. ("Esri")**.

This Agreement sets forth the terms for Customer's use of Products and incorporates by reference (i) the Quotation and (ii) the Master Agreement. Should there be any conflict between the terms and conditions of the documents that comprise this Agreement, the order of precedence for the documents shall be as follows: (i) the Quotation, (ii) this Agreement, and (iii) the Master Agreement. This Agreement shall be governed by and construed in accordance with the laws of the state in which Customer is located without reference to conflict of laws principles, and the United States of America federal law shall govern in matters of intellectual property. The modifications and additional rights granted in this Agreement apply only to the Products listed in Table A.

**Table A
List of Products**

Uncapped Quantities

Desktop Software and Extensions (Single Use)

ArcGIS Desktop Advanced
ArcGIS Desktop Standard
ArcGIS Desktop Basic
ArcGIS Desktop Extensions: ArcGIS 3D Analyst, ArcGIS Spatial Analyst, ArcGIS Geostatistical Analyst, ArcGIS Publisher, ArcGIS Network Analyst, ArcGIS Schematics, ArcGIS Workflow Manager, ArcGIS Data Reviewer

Enterprise Software and Extensions

ArcGIS Enterprise and Workgroup (Advanced and Standard)
ArcGIS Enterprise Extensions: ArcGIS 3D Analyst, ArcGIS Spatial Analyst, ArcGIS Geostatistical Analyst, ArcGIS Network Analyst, ArcGIS Schematics, ArcGIS Workflow Manager

ArcGIS Monitor

Enterprise Additional Capability Servers

ArcGIS Image Server

Developer Tools

ArcGIS Engine
ArcGIS Engine Extensions: ArcGIS 3D Analyst, ArcGIS Spatial Analyst, ArcGIS Engine Geodatabase Update, ArcGIS Network Analyst, ArcGIS Schematics
ArcGIS Runtime (Standard)
ArcGIS Runtime Analysis Extension

Limited Quantities

One (1) Professional subscription to ArcGIS Developer
Two (2) Esri CityEngine Single Use Licenses
50 ArcGIS Online Viewers
50 ArcGIS Online Creators
10,000 ArcGIS Online Service Credits
50 ArcGIS Enterprise Creators
2 Insights in ArcGIS Enterprise
2 Insights in ArcGIS Online
5 Tracker for ArcGIS Enterprise
5 Tracker for ArcGIS Online
2 ArcGIS Parcel Fabric User Type Extensions (Enterprise)
2 ArcGIS Utility Network User Type Extensions (Enterprise)

OTHER BENEFITS

Number of Esri User Conference registrations provided annually	2
Number of Tier 1 Help Desk individuals authorized to call Esri	2
Maximum number of sets of backup media, if requested*	2
Self-Paced e-Learning	Uncapped
Five percent (5%) discount on all individual commercially available instructor-led training classes at Esri facilities purchased outside this Agreement	

*Additional sets of backup media may be purchased for a fee

Customer may accept this Agreement by signing and returning the whole Agreement with (i) the Quotation attached, (ii) a purchase order, or (iii) another document that matches the Quotation and references this Agreement ("**Ordering Document**"). **ADDITIONAL OR CONFLICTING TERMS IN CUSTOMER'S PURCHASE ORDER OR OTHER DOCUMENT WILL NOT APPLY, AND THE TERMS OF THIS AGREEMENT WILL GOVERN.** This Agreement is effective as of the date of Esri's receipt of an Ordering Document, unless otherwise agreed to by the parties ("**Effective Date**").

Term of Agreement: Three (3) years

This Agreement supersedes any previous agreements, proposals, presentations, understandings, and arrangements between the parties relating to the licensing of the Products. Except as provided in Article 4—Product Updates, no modifications can be made to this Agreement.

Accepted and Agreed:

(Customer)

By: _____
Authorized Signature

Printed Name: _____

Title: _____

Date: _____

CUSTOMER CONTACT INFORMATION

Contact: _____

Telephone: _____

Address: _____

Fax: _____

City, State, Postal Code: _____

E-mail: _____

Country: _____

Quotation Number (if applicable): _____

1.0—ADDITIONAL DEFINITIONS

In addition to the definitions provided in the Master Agreement, the following definitions apply to this Agreement:

"Case" means a failure of the Software or Online Services to operate according to the Documentation where such failure substantially impacts operational or functional performance.

"Deploy", "Deployed" and "Deployment" mean to redistribute and install the Products and related Authorization Codes within Customer's organization(s).

"Fee" means the fee set forth in the Quotation.

"Maintenance" means Tier 2 Support, Product updates, and Product patches provided to Customer during the Term of Agreement.

"Master Agreement" means the applicable master agreement for Esri Products incorporated by this reference that is (i) found at <https://www.esri.com/en-us/legal/terms/full-master-agreement> and available in the installation process requiring acceptance by electronic acknowledgment or (ii) a signed Esri master agreement or license agreement that supersedes such electronically acknowledged master agreement.

"Product(s)" means the products identified in Table A—List of Products and any updates to the list Esri provides in writing.

"Quotation" means the offer letter and quotation provided separately to Customer.

"Technical Support" means the technical assistance for attempting resolution of a reported Case through error correction, patches, hot fixes, workarounds, replacement deliveries, or any other type of Product corrections or modifications.

"Tier 1 Help Desk" means Customer's point of contact(s) to provide all Tier 1 Support within Customer's organization(s).

"Tier 1 Support" means the Technical Support provided by the Tier 1 Help Desk.

"Tier 2 Support" means the Esri Technical Support provided to the Tier 1 Help Desk when a Case cannot be resolved through Tier 1 Support.

2.0—ADDITIONAL GRANT OF LICENSE

2.1 Grant of License. Subject to the terms and conditions of this Agreement, Esri grants to Customer a personal, nonexclusive, nontransferable license solely to use, copy, and Deploy quantities of the Products listed in Table A—List of Products for the Term of Agreement (i) for the applicable Fee and (ii) in accordance with the Master Agreement.

2.2 Consultant Access. Esri grants Customer the right to permit Customer's consultants or contractors to use the Products exclusively for Customer's benefit. Customer will be solely responsible for compliance by consultants and contractors with this Agreement and will ensure that the consultant or contractor discontinues use of Products upon completion of work for Customer. Access to or use of Products by consultants or contractors not exclusively for Customer's benefit is prohibited. Customer may not permit its consultants or contractors to install Software or Data on consultant, contractor, or third-party computers or remove Software or Data from Customer locations, except for the purpose of hosting the Software or Data on Contractor servers for the benefit of Customer.

3.0—TERM, TERMINATION, AND EXPIRATION

3.1 Term. This Agreement and all licenses hereunder will commence on the Effective Date and continue for the duration identified in the Term of Agreement, unless this Agreement is terminated earlier as provided herein. Customer is only authorized to use Products during the Term of Agreement. For an Agreement with a limited term, Esri does not grant Customer an indefinite or a perpetual license to Products.

3.2 No Use upon Agreement Expiration or Termination. All Product licenses, all Maintenance, and Esri User Conference registrations terminate upon expiration or termination of this Agreement.

3.3 Termination for a Material Breach. Either party may terminate this Agreement for a material breach by the other party. The breaching party will have thirty (30) days from the date of written notice to cure any material breach.

3.4 Termination for Lack of Funds. For an Agreement with government or government-owned entities, either party may terminate this Agreement before any subsequent year if

Customer is unable to secure funding through the legislative or governing body's approval process.

3.5 Follow-on Term. If the parties enter into another agreement substantially similar to this Agreement for an additional term, the effective date of the follow-on agreement will be the day after the expiration date of this Agreement.

4.0—PRODUCT UPDATES

4.1 Future Updates. Esri reserves the right to update the list of Products in Table A—List of Products by providing written notice to Customer. Customer may continue to use all Products that have been Deployed, but support and upgrades for deleted items may not be available. As new Products are incorporated into the standard program, they will be offered to Customer via written notice for incorporation into the Products schedule at no additional charge. Customer's use of new or updated Products requires Customer to adhere to applicable additional or revised terms and conditions in the Master Agreement.

4.2 Product Life Cycle. During the Term of Agreement, some Products may be retired or may no longer be available to Deploy in the identified quantities. Maintenance will be subject to the individual Product Life Cycle Support Status and Product Life Cycle Support Policy, which can be found at <https://support.esri.com/en/other-resources/product-life-cycle>. Updates for Products in the mature and retired phases may not be available. Customer may continue to use Products already Deployed, but Customer will not be able to Deploy retired Products.

5.0—MAINTENANCE

The Fee includes standard maintenance benefits during the Term of Agreement as specified in the most current applicable Esri Maintenance and Support Program document (found at <https://www.esri.com/en-us/legal/terms/maintenance>). At Esri's sole discretion, Esri may make patches, hot fixes, or updates available for download. No Software other than the defined Products will receive Maintenance. Customer may acquire maintenance for other Software outside this Agreement.

a. Tier 1 Support

1. Customer will provide Tier 1 Support through the Tier 1 Help Desk to all Customer's authorized users.
2. The Tier 1 Help Desk will be fully trained in the Products.
3. At a minimum, Tier 1 Support will include those activities that assist the user in resolving how-to and operational questions as well as questions on installation and troubleshooting procedures.
4. The Tier 1 Help Desk will be the initial point of contact for all questions and reporting of a Case. The Tier 1 Help Desk will obtain a full description of each reported Case and the system configuration from the user. This may include obtaining any customizations, code samples, or data involved in the Case.
5. If the Tier 1 Help Desk cannot resolve the Case, an authorized Tier 1 Help Desk individual may contact Tier 2 Support. The Tier 1 Help Desk will provide support in such a way as to minimize repeat calls and make solutions to problems available to Customer's organization.
6. Tier 1 Help Desk individuals are the only individuals authorized to contact Tier 2 Support. Customer may change the Tier 1 Help Desk individuals by written notice to Esri.

b. Tier 2 Support

1. Tier 2 Support will log the calls received from Tier 1 Help Desk.
2. Tier 2 Support will review all information collected by and received from the Tier 1 Help Desk including preliminary documented troubleshooting provided by the Tier 1 Help Desk when Tier 2 Support is required.
3. Tier 2 Support may request that Tier 1 Help Desk individuals provide verification of information, additional information, or answers to additional questions to supplement any preliminary information gathering or troubleshooting performed by Tier 1 Help Desk.
4. Tier 2 Support will attempt to resolve the Case submitted by Tier 1 Help Desk.

5. When the Case is resolved, Tier 2 Support will communicate the information to Tier 1 Help Desk, and Tier 1 Help Desk will disseminate the resolution to the user(s).

6.0—ENDORSEMENT AND PUBLICITY

This Agreement will not be construed or interpreted as an exclusive dealings agreement or Customer's endorsement of Products. Either party may publicize the existence of this Agreement.

7.0—ADMINISTRATIVE REQUIREMENTS

7.1 OEM Licenses. Under Esri's OEM or Solution OEM programs, OEM partners are authorized to embed or bundle portions of Esri products and services with their application or service. OEM partners' business model, licensing terms and conditions, and pricing are independent of this Agreement. Customer will not seek any discount from the OEM partner or Esri based on the availability of Products under this Agreement. Customer will not decouple Esri products or services from the OEM partners' application or service.

7.2 Annual Report of Deployments. At each anniversary date and ninety (90) calendar days prior to the expiration of this Agreement, Customer will provide Esri with a written report detailing all Deployments. Upon request, Customer will provide records sufficient to verify the accuracy of the annual report.

8.0—ORDERING, ADMINISTRATIVE PROCEDURES, DELIVERY, AND DEPLOYMENT

8.1 Orders, Delivery, and Deployment

- a. Upon the Effective Date, Esri will invoice Customer and provide Authorization Codes to activate the nondestructive copy protection program that enables Customer to download, operate, or allow access to the Products. If this is a multi-year Agreement, Esri may invoice the Fee up to thirty (30) calendar days before the annual anniversary date for each year.
- b. Undisputed invoices will be due and payable within thirty (30) calendar days from the date of invoice. Esri reserves the right to suspend Customer's access to and use of Products if

Customer fails to pay any undisputed amount owed on or before its due date. Esri may charge Customer interest at a monthly rate equal to the lesser of one percent (1.0%) per month or the maximum rate permitted by applicable law on any overdue fees plus all expenses of collection for any overdue balance that remains unpaid ten (10) days after Esri has notified Customer of the past-due balance.

- c. Esri's federal ID number is 95-2775-732.
 - d. If requested, Esri will ship backup media to the ship-to address identified on the Ordering Document, FOB Destination, with shipping charges prepaid. Customer acknowledges that should sales or use taxes become due as a result of any shipments of tangible media, Esri has a right to invoice and Customer will pay any such sales or use tax associated with the receipt of tangible media.
- 8.2 Order Requirements.** Esri does not require Customer to issue a purchase order. Customer may submit a purchase order in accordance with its own process requirements, provided that if Customer issues a purchase order, Customer will submit its initial purchase order on the Effective Date. If this is a multi-year Agreement, Customer will submit subsequent purchase orders to Esri at least thirty (30) calendar days before the annual anniversary date for each year.
- a. All orders pertaining to this Agreement will be processed through Customer's centralized point of contact.
 - b. The following information will be included in each Ordering Document:
 - (1) Customer name; Esri customer number, if known; and bill-to and ship-to addresses
 - (2) Order number
 - (3) Applicable annual payment due

9.0—MERGERS, ACQUISITIONS, OR DIVESTITURES

If Customer is a commercial entity, Customer will notify Esri in writing in the event of (i) a consolidation, merger, or reorganization of Customer with or into another corporation or entity; (ii) Customer's acquisition of another entity; or (iii) a transfer or sale of all or part of Customer's organization (subsections i, ii, and iii, collectively referred to as "**Ownership Change**"). There will be

no decrease in Fee as a result of any Ownership Change.

- 9.1** If an Ownership Change increases the cumulative program count beyond the maximum level for this Agreement, Esri reserves the right to increase the Fee or terminate this Agreement and the parties will negotiate a new agreement.
- 9.2** If an Ownership Change results in transfer or sale of a portion of Customer's organization, that portion of Customer's organization will transfer the Products to Customer or uninstall, remove, and destroy all copies of the Products.
- 9.3** This Agreement may not be assigned to a successor entity as a result of an Ownership Change unless approved by Esri in writing in advance. If the assignment to the new entity is not approved, Customer will require any successor entity to uninstall, remove, and destroy the Products. This Agreement will terminate upon such Ownership Change.



AGENDA ITEM

Administration 11. H.

City Council Regular

Meeting Date: April 20, 2020

Submitted By: Pam Vann, Finance Director

Department: Finance

Presented By: Pam Vann

SUBJECT:

Discussion and possible action regarding a Disaster Assistance Agreement for Major Disasters between the State of Oklahoma and the City of Sapulpa for disaster assistance resulting from Oklahoma DR 4530 COVID-19 and authorize the Mayor Pro Tem to execute all necessary documents.

BACKGROUND:

In order for the City to receive any funding from the Oklahoma Department of Emergency Management for the DR 4530 COVID-19 disaster a formal agreement must be executed.

RECOMMENDATION:

Staff recommends approval of this agreement.

Attachments

Disaster Assistance Agreement-COVID 19

**Oklahoma DR-4530 COVID-19
Formerly (EM-3462)
STATE – LOCAL AGREEMENT**



**DISASTER ASSISTANCE AGREEMENT FOR MAJOR
DISASTERS**

Between

STATE OF OKLAHOMA

And

Sapulpa, City Of

(Local Applicant)

Entered into this 13 day of Apr, 2020

This agreement is between the State of Oklahoma, executed by the Governor's Authorized Representative (GAR) or State Coordinating Officer (SCO) for the Oklahoma Department of Emergency Management (OEM), and Sapulpa, City Of ("Local Applicant"). This agreement shall apply to all assistance funds provided through or by the State of Oklahoma to the Applicant based on damages resulting from **Oklahoma DR 4530 COVID-19**, incident period **January 20, 2020 and continuing**, pursuant to the Major Disaster Declaration signed by the President of the United States, dated **April 1, 2020**.

EXECUTION OF THE AGREEMENT

SIGNATURE AUTHORITY

Once your Request for Public Assistance (RPA) has been approved, it is now necessary for you, as the Subgrantee/Subrecipient, to enter into the attached Agreement with the Oklahoma Department of Emergency Management (OEM). Hereafter referred to as the Grantee/Recipient. The following specific officers/officials, or their authorized designees, are required to sign this Agreement on behalf of the specified type of Subgrantee/Subrecipient. (NOTE: If this Agreement is signed by a designee, a duly authenticated delegation of authority evidencing the signer's authority to execute the Agreement for, and on behalf of, the Subgrantee/Subrecipient must be attached to the Agreement for review by OEM).

- a. **Corporation:** the Chair of the Board of Directors or President;
- b. **City:** the Mayor, City Manager, or Town Administrator
- c. **County:** the Chair of the County Commissioners
- d. **School Board:** the Superintendent
- e. **Fire District:** the district Chief
- f. **Special Districts:** the Executive Director
- g. **Institution of Higher Education:** the President of the institution
- h. **Charter School:** the Chair of the Board of Directors
- i. **County Sheriff's Office:** the Sheriff
- j. **State Agencies:** the Director or Deputy Director of the agency
- k. **All other Sub-grantee / Sub-recipients:** the Chief Executive Officer of the entity

Copies of this Agreement may be obtained by anyone authorized to access OK.EMGrants.com.

The Applicant certifies and acknowledges:

1. The State of Oklahoma has legal authority to apply for assistance on behalf of the Applicant.
2. The Applicant must use disaster assistance funds solely for the purposes as stated in the approved project worksheets (PW) and the agreed upon scope of work approved by the Federal Emergency Management Agency (FEMA) and the State.
3. The Applicant is aware of, and shall be responsible for, the cost-sharing requirements of federal and state disaster assistance as stipulated in the President's Major Disaster Declaration, dated April 1, 2020. Specifically, federal assistance, in most instances, is limited to 75% of eligible expenditures. State assistance, if applicable, is limited to 12.5% of eligible costs and the Applicant shall provide, from the Applicants funds, the remaining 12.5% of eligible costs. Generally, State Agencies do not participate in the non-federal share and approved participation in available pilot projects may affect the Applicant's non-federal share requirements.
4. **Oklahoma DR 4530 - COVID-19** includes the Public Assistance Program Category B - Emergency Protective Measures and Direct Federal Assistance. Additional designations may be made at a later date after further evaluation.
5. The Applicant is aware that limited funding may be made available for mitigation of future disaster damages which requires cost-sharing on the basis of 75% federal and 25% non-federal contribution and that the Applicant may be required to provide the full non-federal contribution for such mitigation activities.
6. The Applicant must establish and maintain a proper accounting system to record expenditures of disaster assistance funds in accordance with generally accepted accounting standards. The accounting system must follow the approved practices as outlined in 2 CFR part 200.
7. The Applicant is aware all disaster assistance funding will be provided on a reimbursement basis only and must follow the reimbursement processes established by OEM/FEMA grant guidelines.
8. The Applicant shall accurately document the events and expenses incurred in the disaster response and recovery. All documentation pertaining to a project shall be filed together with the corresponding PW and maintained by the Applicant as the permanent record of the project in accordance with all documentation retention requirements. This process must include all backup and corresponding documentation attached to the PW in each file. The applicant must provide a copy of the documentation to the State for review, reconciliation, and archiving.
9. The Applicant's records and supporting documentation relating to claims shall be kept for seven (7) years after the completion and final payment of an individual PW and shall be available for inspection and audit at all reasonable times by the Oklahoma Department of Emergency Management, Oklahoma Office of the State Auditor and

Inspector (SAI) and the US Department of Homeland Security Office of Inspector General (OIG).

10. The Applicant shall give the appropriate State agencies, as designated by OEM, access to and the right to examine all records, documents, and papers relating to any activity undertaken for funding under this agreement.
11. The Applicant shall provide OEM with quarterly project status reports on all large (greater than \$131,100) projects. Also, if the Applicant expends \$750,000 or more in total Federal assistance (all programs) in a single year, the Applicant shall accomplish a "single audit" and submit a copy of that audit to OEM in accordance with Title 2 of the Code of Federal Regulations 200.501. This may be provided to OEM by properly uploading to the Federal Audit Clearing House or by email at Single.Audit@oem.ok.gov.
12. The Applicant shall comply with the U.S. Environmental Protection Agency regulations contained in Title 40 of the Code of Federal Regulations.
13. The Applicant shall comply with all applicable provisions of State laws and regulations in regard to procurement of goods and services regarding contracts for repair or restoration of public facilities which conform to federal law and the standards identified in 2 CFR §§ 200.317-200.326.
12. The Applicant affirms they have not received duplicate benefits from another source for projects related to this disaster. If the Applicant receives duplicate benefits from another source for projects related to this disaster, the Applicant agrees to refund the benefits provided by the State.
14. The Applicant shall comply with provisions of the Hatch Act of 1939 limiting the political activities of public employees, as it relates to the programs funded.
15. The Applicant shall comply, as applicable, with the provisions of the Davis-Bacon Act relating to labor standards.
16. The Applicant shall not enter into any cost plus percentage of costs or contingency contract for completion of disaster restoration or repair work.
17. The Applicant shall not enter into contracts, grants, loans or cooperative agreements for which payment is contingent upon receipt of state or federal funds.
18. The Applicant must not enter into any contract with any party that has been prohibited from participating in federal or state assistance programs. Entities will be verified through SAM.GOV.

19. As a condition for receipt of state or federal funds, the Applicant certifies that it has the legal responsibility for the disaster repair and/or restoration of all facilities for which it is applying for disaster assistance.
20. The Applicant certifies that it has all necessary lands, easements, rights-of-way and accesses necessary to complete the Public Assistance projects for which it has and/or will apply. The Applicant agrees and understands that neither the State nor FEMA will be responsible for obtaining any land, easement, right-of-way and/or access necessary to perform work on an approved project.
21. The Applicant agrees to indemnify and hold the State and FEMA harmless from any damages arising out of the projects funded under this agreement.
22. The Applicant understands and will abide by the following work completion deadlines:
 - Emergency Work (Category A & B) – Six months from the date of declaration.
 - Permanent Work (Category C – G) – Eighteen months from the date of declaration.

Extensions will only be granted solely for conditions or causes which are beyond the Applicant's control.
23. All required documentation in support of the large project costs for closeout will be **submitted within 60 days** following completion of physical work on the project.
24. Time Extensions will be granted solely for conditions beyond the Applicant's control, which result in an inability to complete approved projects within the approved timeline. All extensions will be subject to approval of the OEM Public Assistance Officer or OEM Recovery Programs Director or their designee and must be requested by the applicant in writing.
25. The Applicant will, at the completion of all small projects, request through OK.EMGrants.com a small project validation. Once completed, this will generate the 12.5% State share payment where applicable.
26. The Applicant will verify Electronic Transfer of Funds is in place.
27. By signing this agreement, the Applicant further acknowledges that the effective date of this agreement shall be as of the date of the Federal Declaration of Disaster dated **April 1, 2020.**

I hereby appoint:

_____ **job title** _____

and/or

_____ job title _____

to act on behalf of my jurisdiction regarding Oklahoma DR 4530 - COVID-19.

I acknowledge by my signature, I am aware should any part of this agreement not be in compliance with all regulations, funding for this and possibly future disasters, will be jeopardized.

Signed: _____
LOCAL SIGNATURE AUTHORITY **TITLE**

STATE OF OKLAHOMA

COUNTY OF _____

Signed or attested before me on _____ (date),

by _____ name(s) of person(s).

NOTARY PUBLIC

Notary Public Signature: _____

Printed Name: _____

My Commission Expires: _____

STATE USE ONLY

APPROVED on this _____ Day of _____, 20_____

Signed: _____

Governor's Authorized Representative or State Coordinating Officer